



Australian Government
Australian Transport Safety Bureau

Derailment of Sydney Trains Passenger Train 602M

near Edgecliff station, Sydney, NSW | 15 January 2014



Investigation

ATSB Transport Safety Report
Rail Occurrence Investigation
RO-2014-001
Final – 3 December 2015

Cover photo: 602M after derailling

Source: OTSI

This investigation was conducted under the *Transport Safety Investigation Act 2003* (Cth) by the Office of Transport Safety Investigations (NSW) on behalf of the Australian Transport Safety Bureau in accordance with the Collaboration Agreement entered into on 18 January 2013.

Released in accordance with s25 of the *Transport Safety Investigation Act 2003*

Publishing information

Published by: Australian Transport Safety Bureau
Postal address: PO Box 967, Civic Square ACT 2608
Office: 62 Northbourne Avenue Canberra, Australian Capital Territory 2601
Telephone: 1800 020 616, from overseas +61 2 6257 4150 (24 hours)
Accident and incident notification: 1800 011 034 (24 hours)
Facsimile: 02 6247 3117, from overseas +61 2 6247 3117
Email: atsbinfo@atsb.gov.au
Internet: www.atsb.gov.au

© Commonwealth of Australia 2015



Ownership of intellectual property rights in this publication

Unless otherwise noted, copyright (and any other intellectual property rights, if any) in this publication is owned by the Commonwealth of Australia.

Creative Commons licence

With the exception of the Coat of Arms, ATSB logo, and photos and graphics in which a third party holds copyright, this publication is licensed under a Creative Commons Attribution 3.0 Australia licence.

Creative Commons Attribution 3.0 Australia Licence is a standard form license agreement that allows you to copy, distribute, transmit and adapt this publication provided that you attribute the work.

The ATSB's preference is that you attribute this publication (and any material sourced from it) using the following wording: *Source:* Australian Transport Safety Bureau

Copyright in material obtained from other agencies, private individuals or organisations, belongs to those agencies, individuals or organisations. Where you want to use their material you will need to contact them directly.

Addendum

Page	Change	Date
6,16	Train direction on figures corrected	11/12/15
14	Overhead traction sytem text amended	11/12/15
36	Reference to 'invoice' amended to 'quotation'	3/2/2016

Safety summary

What happened

At about 1654 on 15 January 2014, a Sydney Trains service made up of two four-carriage Tangara electric multiple units, entered the underground section of the Eastern Suburbs Line under Sydney city centre heading towards its destination, Bondi Junction. Some smoke and a burning smell were apparent emanating from the train at Central station and at all subsequent stations to Bondi Junction. A number of station and train crewing staff were aware of this but the condition was not reported to the appropriate network control officer as required under Sydney Trains' Network Rules and Procedures.

The train terminated at Bondi Junction where a different driver took control of the train before it departed on its return journey. It then travelled to the next station, Edgecliff. Shortly after departure from Edgecliff, at 1726, the lead bogie of the third carriage derailed due to a broken axle on the leading bogie of the third carriage. A piece of angle iron that became dislodged from the track infrastructure penetrated the floor of the third carriage and entered a space occupied by passengers.

What the ATSB found

The ATSB found that an unauthorised, non-standard repair had been carried out on the axle in December 1998 or January 1999 which introduced stress initiators, causing a crack to develop which over time propagated to the extent that the axle failed in service.

It was also determined that a number of organisational factors contributed to the incident with examples of poor communication and lack of adherence to procedures and reporting lines leading to the train continuing in service and subsequently derailing.

What has been done as a result

Sydney Trains and their maintenance contractors undertook an archival document search and determined that seven axles, including the failed axle, had been repaired in the same way. All were immediately removed from service.

Sydney Trains, after conducting its own investigation into the circumstances surrounding the incident, produced a number of safety recommendations which the organisation is considering through its own Safety Action Management procedures.

Safety message

Rail operators should ensure that maintenance procedures are followed and that non-standard repairs comply strictly with an approved variation and do not introduce new risks to operations.

Also, rail operators should review their internal training and communication pathways both within and between business units / operational areas to ensure that critical communication can occur in line with best current Rail Resource Management principles.

Motor resting on rail head



Source: Office of Transport Safety Investigations (OTSI)

Contents

The occurrence	1
Events prior to derailment	1
The derailment	4
Second movement	6
Post incident	7
Context	10
Location	10
Organisation	12
Infrastructure	13
Site observations	14
Rolling stock	16
Metallurgical investigation	18
Operational staff	23
Operations at Bondi Junction	26
Rules and Procedures	27
Emergency response management	28
Sydney Trains post incident debrief	29
Rail resource management / risk based training needs analysis	29
Other incidents	30
Safety analysis	34
Repair procedures	35
Non-destructive testing	35
Track condition	36
Effectiveness of incident response	36
Training	38
Responding to WSLs	39
In conclusion	40
Findings	41
Contributing factors	41
Other factors that increased risk	41
Other findings	41
Safety issues and actions	43
Additional safety action	46
General details	48
Occurrence details	48
Train details	48
Sources and submissions	49
Sources of information	49
References	49
Submissions	49

Appendices	51
The occurrence	52
Axle description and design	53
Physical examination	54
<i>Examination methods</i>	54
Safety analysis.....	64
Appendix B – Rail Resource Management	66
Appendix C – Main communications channels	68
Australian Transport Safety Bureau	70
Purpose of safety investigations	70
Developing safety action	70

The occurrence

Events prior to derailment

Background

Passenger service 602M consisted of two 4-carriage electric multiple unit Tangara sets, T10 and T35, coupled together to form an 8-carriage train.

Carriage N5222 of T10 had the bogie with the incident axle fitted as part of routine maintenance in January 2012. The drive axle concerned had previously been inspected in September 2011 when it was found necessary to replace the crown wheel as it was cracked. No other defects had been identified during visual inspection or non-destructive testing of the axle. No faults had been reported in relation to this axle or the bogie prior to the day of the incident.

Service 602L

In the afternoon of 15 January 2014 sets T10 and T35 formed a train, designated run 602L, operating between Cronulla in Sydney’s south-east and Bondi Junction in Sydney’s eastern suburbs (Figure 1). The train departed from Cronulla at 1604:50 EDT,¹ (approximately two minutes late, when compared to the timetable). It was driven by a trainee driver under the supervision of a driver trainer. The journey was initially overground through Sydney suburbia on the Cronulla branch line before joining the Illawarra line at Sutherland. Between Sutherland and the next station, Jannali, the wheel slip light (WSL) illuminated for four seconds during braking. For the rest of the journey, according to analysis of the data logger download, the WSL illuminated 20 more times at irregular intervals before arrival at Redfern station.

Figure 1: Route of Run 602L from Cronulla



Source: Sydney Trains

¹ All times referred to in this report are Eastern Daylight-saving Time (EDT), Coordinated Universal Time (UTC) + 11 hours.

The train crew members present in the cab, including another driver who had joined the train at Mortdale, reported that they did not observe these illuminations. No illuminations were recorded between Redfern and Central stations where the trainee and driver trainer alighted and the other driver took over driving duties.

At Central, a train crew shift manager (TCSM) on duty on platform number 24, an underground platform, noticed a burning smell and smoke towards the rear of the train. The TCSM hurried towards the rear of the train and looked inside and around the last carriage. He was joined by another TCSM. A customer service attendant (CSA) was waiting to raise a white flag to signal a right of way for the guard to commence the closing of doors and departure sequence. The guard was travelling in the leading end of the fifth carriage, as is normal for that class of train. The TCSM reported the smoke and odour by phone to the train crewing liaison officer (TCLO) located within the Rail Management Centre (RMC). CCTV images show the first TCSM talking on his mobile phone during the latter part of the inspection. Having completed his inspection, the TCSM signalled to the CSA to allow the train to proceed. CCTV images show a smoky haze towards the rear of the train. The haze was not present prior to the train's arrival.

CCTV images show a member of the public, at the Redfern end where the rear of the train had been, sniffing the air and looking up and about apparently for the source of a smell, about a minute after the train departed.

The information regarding the smoke and odour was also passed on to a CSA at the next station, Town Hall. At Town Hall, the CSA informed the train's guard. At interview the guard stated that he could not see or smell anything and there was no noise or any other indication that there was a problem with the train. The train continued towards Martin Place. A little over half way between Town Hall and Martin Place the WSL illuminated for four seconds while the train was coasting. The driver reported that he was unaware of this. The train stopped at Martin Place, passengers got on and off as usual and the train departed.

The burning smell rose to the concourse level where the Martin Place duty manager (DM) was located. The smell was of an intensity and nature that prompted the DM to call the Sydney Trains Emergency Response Unit (STERU). He requested that the unit attend, in case there was a fire on the station premises. The DM identified the burning smell as being similar to tyres burning.

En route to Kings Cross, the guard called the driver to inform him of the report of smoke and a burning smell, as relayed to him by the CSA at Town Hall. The guard commented that he hadn't smelt anything and, in his position in the front of the train, neither had the driver. However, while they were having this conversation, the driver noticed a fault indication on his Train Management System (TMS) screen which indicated that there was a fault on the sixth position carriage. The driver asked the guard to check the train at the next station, Kings Cross. Between Martin Place and Kings Cross, a journey that took a second less than two minutes, the WSL came on seven times, including once for five seconds about 30 seconds before Kings Cross. On arrival at Kings Cross the guard and a staff member who was on the platform inspected the suspect carriage from the platform and internally before the train continued. The guard called the driver again and confirmed that beyond 'a bit of a smell' he could discern nothing wrong.

After departing Kings Cross, the driver called the fleet operations controller, located within the RMC, and reported the sequence of events since Central. He stated that he had a repeated indication of a wheel slip protection (WSP) brake fault on carriage N5222 and that the WSL was flickering. As the train arrived at Edgecliff, at 1724:45 CCTV images show sparks emitting from the trailing bogie of the sixth carriage.

At about the same time, a train heading in the other direction reported to Network Control that there was a smouldering wooden half sleeper on the viaduct between Edgecliff and Kings Cross.

Edgecliff did not have platform staff and neither the guard nor the driver (who stepped out of his cab to look along the train) noticed anything unusual. The train then continued to the line's terminus, Bondi Junction. En route, the driver asked the guard to tell the incoming driver at Bondi

Junction of the issues with the train. This was necessary because, at Bondi Junction, the incoming driver was stationed at the opposite end of the train to the outgoing driver. Between Kings Cross and Bondi Junction, the WSL came on 14 times.

As Run 602L travelled between Central and Bondi Junction a number of conversations about the train took place variously between station staff, train crewing staff, train crew and various positions within Sydney Trains' RMC. However, no formal incident or condition report was made in conformance with Sydney Trains' rules and procedures and no one person was aware of all the facts.

Turnaround at Bondi Junction

On arrival at Bondi Junction another driver trainer and a trainee were waiting to take over control of the train. They walked to the Sydney end of platform 1 as the train arrived. Once the train was stationary, the original driver made an emergency brake application (normal procedure), applied the parking brake and cut out his controls. He then left his cab and, noticing that there was 'quite a plume of smoke', walked briskly to the centre of the train. On the way, he spoke to a TCSM (one of two on duty at the time) who went to fetch the second TCSM who was an ex-Operations Standards Manager² who had driving and fault-finding experience.

The driver trainer had also observed that there was an issue and, leaving the trainee driver in the cab, walked back to the centre of the train from the Sydney end. The original driver reported that he voiced his concerns to the driver trainer; however, the driver trainer (at interview) said he did not recall this. The driver trainer did recall that the smell was 'between brake pads and oil' and because of this he had considered the possibility of there being a problem with an air compressor. The original driver also spoke further to both of the TCSMs and inspected the suspect area of the train from the platform with the second TCSM. The second TCSM was also talking on his mobile phone to the TCLO in the RMC. The original driver commented, 'there was a lot going on'. It was apparent to him that a decision had been made for the train to continue in service.

Meanwhile, as requested by the original driver, the guard passed on the message about the issues with the train. However, as the driver trainer was on the platform, the message was received by the trainee who was then in the cab on his own. Under the instruction of the driver trainer the trainee had cut in his controls and the brake pipe recharged (that is, built up air pressure). He was then instructed by the driver trainer to make an emergency brake application. This reduced the brake pipe pressure to zero once more. This is the procedure commonly applied when sticking brakes are suspected.

A CSA on the platform had noticed an unusual vibration and heavy smoke coming from carriage N5222 on its arrival. The CSA became increasingly concerned about the amount of smoke present and the burning smell and made an emergency 'fire fire fire' broadcast on his hand held radio to alert other station staff. The DM called the Security Control Centre (SCC) within the RMC to request the attendance of STERU and NSW Fire and Rescue. STERU, who were still proceeding to Martin Place, were asked to respond (that is, travel with lights and sirens on) to Bondi Junction. NSW Fire and Rescue were also requested to attend by the SCC.

An intending wheelchair passenger and attendant were present on the platform but the CSA declined to allow them to board, advising them to proceed to the other platform, platform 2, as he did not expect the train on platform 1, now designated 602M, to depart.

Station staff state that the driver was notified that emergency services were en route but the driver cannot recall this. Train crewing staff assumed that the issue was caused by sticking brakes and decided to allow the train to continue in service to Central where a train technician would be available to inspect it. Since the train was now travelling in the opposite direction, the incident carriage was the third carriage of the new run. The trainee driver was in control of the train and,

² Operations Standards Manager: (OSM) a position under the previous RailCorp structure.

with the driver trainer supervising and the second TCSM in the third carriage, 602M departed from Bondi Junction back towards Sydney CBD.

Service 602M

Incident train 602M was overdue for departure from Bondi Junction. The driver trainer who had met the train at Bondi Junction and was now in charge of it had, in consultation with the second TCSM and through him to the TCLO in RMC, decided to proceed. 602M departed at 1721. The TCSM rode in the train to listen for any abnormal sounds, especially in the suspect carriage. The train departed, and STERU (now an estimated two or three minutes away from Bondi Junction) and NSW Fire and Rescue were stood down. STERU was asked to proceed to Central where, along with a train technician, they would inspect the train.

Between Bondi Junction and Edgecliff the TCSM did not detect any abnormalities from within the passenger areas of the train other than a sound indicating a possible wheel flat, usually caused by a wheel locking up under braking, which is very rare in a Tangara. At interview, both the driver trainer and trainee stated that they received no WSL indications. However, the data logger recorded a two second pulse about 30 seconds after departure and multiple pulses over 11 seconds about 30 seconds before arrival at Edgecliff. En route and in between these wheel slip events, the crew switched the train's brakes from the usual electro-pneumatic (EP) mode to the stand-by automatic mode and made two brake applications before returning the brake setting to EP. This was intended to assist in clearing any sticking brakes on the train.

On arrival at Edgecliff a CSA was present on the platform in anticipation of the alighting wheelchair passenger (who was not on the train). When the train pulled in the CSA '...saw a lot of smoke' and noted a burning smell emanating from the train. He spoke to the guard about his concerns for the train. He also communicated his concerns to the DM who could smell the train from the concourse level and he supported the CSA's advice that the train should not proceed. The guard, who was speaking on his personal mobile telephone, acknowledged the CSA's comments but took no further action. Meanwhile, the TCSM made his way back to the driver's cab. The train departed from Edgecliff at 1726.

The derailment

As Run 602M departed from platform 1 of Edgecliff Station one wheel of the leading axle of the third carriage, N5222, derailed just beyond the end of the platform. The right hand wheel (in the direction of travel) of the leading axle of the first bogie had slipped into the space between the two rails at 4.668 km. The wheel continued in a derailed state for 17 m where it collided with a concrete slab used to allow road / rail maintenance vehicles to be put on or taken off track. This is evidenced by the damage apparent to the concrete. Lengths of 'angle iron', pieces of steel formed into a right angle section, were fitted to protect the edge of the slab. The first one began a short distance after the start of the slab. This piece was dislodged by the wheel and remained in the flange way between the slab and the rail (Figure 2).

Figure 2: Concrete Slab with displaced angle iron



Source: OTSI

The second piece of angle iron was also dislodged and was picked up by the derailed train. Approximately 25 m beyond the slab there was a set of points which allowed trains that had terminated on the other platform to return towards Central and join the track that 602M was travelling on. The derailed wheel interacted with this set of points such that the other wheel on the axle and both wheels on the bogie's other axle also derailed towards the outside of the rail corridor (that is, towards the left in direction of travel).

The driver trainer, standing behind the trainee, observed the WSL come on and felt the train markedly decelerate. He reached over the trainee and applied the brakes to bring the train to a stand. One end of the piece of angle iron, that had been removed from the concrete pad and caught under the train, fouled on a piece of infrastructure causing the other end to wrap around the second axle on the bogie. It bent upwards, penetrating the vestibule floor and entering the passenger space. The angle iron continued upwards, missing passengers in the area, before marking the carriage's ceiling. The angle iron fell back slightly from this position, remaining stuck through the floor with its end above head height (Figure 3). The train came to a stand after travelling a little over 200 m with the lead bogie of the third carriage derailed.

Figure 3: Angle Iron secured inside carriage N5222



Source: OTSI

The driver trainer immediately directed (using hand signals) the driver of Run 603L, which was approaching from the opposite direction, to stop. He then initiated an emergency call using the train radio. The call was automatically directed to the controlling signaller (located within Sydney Signal Box) but it failed to connect. After a 30 second time-out, the call was transferred to the Illawarra train controller. After a further 16 seconds, the Illawarra train controller (TC) answered the call. The driver trainer reported ‘...I’m not too sure if I’ve got a locked axle or not.’ He then went on to say that he had a faulty parking brake indication on carriage N5222. (Note: At interview the TC stated that he did not hear the reference to a possible locked axle). The conversation then focused on a likely parking brake failure and the TC asked if the driver could release it before trying to proceed. The signaller called RMC during the above conversation and the call was answered by the TC’s supervisor. A discussion took place about how to manage rail traffic on the Eastern Suburbs Railway (ESR). Meanwhile, in parallel, the TCSM who was now in the cab was also talking to the TCLO on his mobile phone about the train’s issues.

Second movement

The driver trainer built up air but the parking brake fault indication remained. The driver trainer looked out along the side of the train but could see nothing untoward. He remained unaware of the train’s derailed state. The driver trainer intended to take the train to the next station, Kings Cross. He used a partial throttle setting (second notch of four) and reached a maximum speed of 17 km/h. The WSL came on along with a fault indication on the TMS screen, so the driver brought the train to a stand again. During this movement, or immediately after, passengers knocked on the driver’s compartment door to alert him to a problem. Passengers also pressed the emergency communication buttons but these were not responded to by the train crew. The train had travelled approximately 120 m in 41 seconds with one bogie in a derailed state (Figure 4).

The driver trainer was now aware that the train had derailed and informed the signaller of this via another emergency train radio call. The signaller immediately set the appropriate signals to stop to protect the area of the derailed train before informing the TC. At the same time, the TCSM informed the TCLO of the derailment who then also informed the TC.

The driver of the other train, stationary on the down track, noticed that 602M was derailed as the derailed carriage moved towards and past his location.

Figure 4: Run 602M after derailing



Source: OTSI

Passengers

There were an estimated 700 passengers on board 602M. Some were standing in the vestibule area at the front of carriage N5222 during the incident, close to where the angle iron penetrated the passenger space. Some passengers pressed the emergency communication button and / or ran through the train to knock on the drivers' compartment door to alert the crew after the train moved off again.

One female passenger was reported to have been about 0.5 m from the location where the angle iron penetrated the floor with its end rising to the roof. She suffered shock from the incident and was assessed on site by ambulance officers. Otherwise, no injuries were reported.

Post incident

Incident notification

The RMC shift manager attempted to contact the Sydney Trains on-call officer a number of times, but the calls went unanswered. The Sydney Trains on-call officer duties included notifying the Australian Transport Safety Bureau (ATSB) of the incident. However, through social media and news media reports the state-based Office of Transport Safety Investigations (OTSI) and NSW personnel of the Office of the National Rail Safety Regulator (ONRSR) became aware of the incident. Two OTSI investigators deployed to the incident location on behalf of the ATSB, arriving at about 1900. ONRSR representatives attended also.

Emergency response coordination

The STERU unit that had arrived at Central to meet 602M was now requested to respond to its derailment at Edgecliff. The unit arrived between 1740 and 1745. Units of NSW Fire and Rescue, Ambulance and Police also attended as did a second STERU vehicle, arriving at 1800.

As well as STERU, the Sydney Trains Incident Emergency Response Unit included Incident Rail Commanders (IRC). However, IRCs were operationally under the direction of the RMC Shift Manager (RMC SM). There was only one IRC on duty in the Sydney metropolitan area at the time of the incident and he had been deployed to an infrastructure failure at Glenfield Junction, about 43 km from the derailment site. The failure had been rectified shortly before the derailment and so, when the IRC was notified at 1735, he was able to set off immediately to attend the site. However, unlike STERU, the IRC did not have an emergency response vehicle and therefore he had to travel through the evening peak period traffic obeying the road rules. The IRC arrived at the site at 1845, after 602M had been evacuated. The IRC then assumed control and coordination of the site for Sydney Trains.

An off-duty IRC who was in Sutherland, about 30 km from the derailment site was also contacted to attend the derailment site, arriving about 20 minutes after the first.

While the IRCs were en route, the TCLO continued to direct the actions of the TCSM while the RMC SM decided, in the absence of an IRC, to use the guards of the two trains 602M and 603L as site contacts. On arrival, the officer in charge of the STERU unit (who reported to the SCC manager in the RMC) coordinated with the emergency services and other Sydney Trains employees on site: the guards, drivers, another driver who had been travelling as a passenger on 602M and the TCLO. In the absence of an IRC, procedures indicate that an Officer in Charge (OIC) is appointed, by default, on site. However, until the IRC arrived, no individual person on site co-ordinated Sydney Trains activities.

The station staff at Edgecliff could see Run 602M just outside the station but were unaware of the fact that it had derailed. The duty manager received a call from Electrical Control who asked if the electrical overhead wires were down but the DM asserted that there was no such incident. An intending passenger, who had been hoping to catch a later train, told him that a relative on the train had called her by mobile phone and said that it had derailed. Emergency services started to arrive and told staff at Edgecliff Station that the train had derailed. The train information boards (controlled from the RMC) still showed train destinations and no advice was received from Sydney Trains operations staff at the RMC about the incident. However, on realisation that an incident had taken place the DM and his staff took action to stop selling tickets, prevent members of the public from entering the station and made suitable announcements giving information to people waiting on the platforms.

Passenger evacuation

In the absence of an IRC, train crewing employees on site prepared to evacuate the passengers on-board 602M. Two possibilities were considered: moving all the passengers into the rear portion of 602M and returning to Edgecliff or transferring the passengers to 603L, stationary on the adjacent line, via the guards' compartments in the centre of the trains. On the arrival of the IERU at 1740, the team leader took a leadership role in passenger evacuation and emergency service coordination on site. Evacuation ladders, available at intervals beside the track, were fitted to the front and rear of 602M and 603L respectively. The access door on the front of 602M had to be secured in the open position by a rope. This was due to the angle of the carriage which otherwise caused the door to shut under the effect of gravity. Once the ladders were in position and the door secured, the evacuation of passengers from 602M to 603L commenced. By 1830, the evacuation had been completed without incident and the passengers were aboard 603L. This train took them to Edgecliff station.

Other trains

In addition to 602M, a total of nine other trains approaching the incident site were either alongside platforms or stationary in tunnels immediately after the derailment. These trains were managed such that, if necessary, they were brought at least partially onto platforms so that passengers could disembark. Once the evacuation of 602M was complete, one of these trains was advanced from Kings Cross to Bondi Junction past the derailment site.

Vehicle recovery

The pantographs on 602M were lowered to allow the derailed bogie to be railed by Sydney Trains' Emergency Train Rescue Unit and the broken axle was placed on a pony bogie (Figure 5) to support it on the journey to Mortdale Maintenance Centre (MMC). Once railing was complete, the pantographs were raised again to allow the train to move under its own power to MMC. The transfer was at a reduced speed, as dictated by the use of a pony bogie.

Figure 5: Axle supported by pony bogie after recovery



Source: OTSI

When the train was inspected at MMC on 16 January, it was found that power had not been isolated from the derailed bogie during the train's transfer to MMC resulting in multiple TMS fault codes being generated. This caused the TMS, which has limited memory, to over-write the incident fault codes. This meant that only the data logger, which does not record the same operational parameters, was available for analysis.

The incident bogie was removed from carriage N5222 and transported by road to UGL-Unipart's facility at Maintrain, Auburn. The train itself was later transferred by rail to Maintrain for further examination and repair.

Post incident crew management

The crew were breath tested at the train by the NSW Police and then, once they had been relieved by another crew, made their way to Edgecliff Station. There was some discussion about whether drug testing was to be conducted at Edgecliff or Central stations. The guard departed for Central and could not be contacted subsequently. Shortly after 2000, the others (the driver trainer, the trainee driver and the TCSM) were tested for the presence of drugs at Edgecliff station by Sydney Trains' contractors. The drivers and the TCSM left the site and were transported to MMC. At MMC they were interviewed by Sydney Trains (train crewing) management, eventually departing for home at about 0100 on 16 January.

Infrastructure repairs

Repairs to infrastructure, sufficient to allow trains to run, were completed overnight and the line was reopened at 0436 in time for the next day's timetabled services. However, the crossover was booked out of use pending later replacement of damaged components. The main route was available for use, allowing train services to recommence.

Context

Location

The derailment of 602M occurred on the Up Eastern Suburbs Railway Line as it was departing Edgecliff Station which was located approximately 4.8 km by rail from Central Station, Sydney (Figure 6).

Figure 6: Eastern Suburbs Rail line diagram

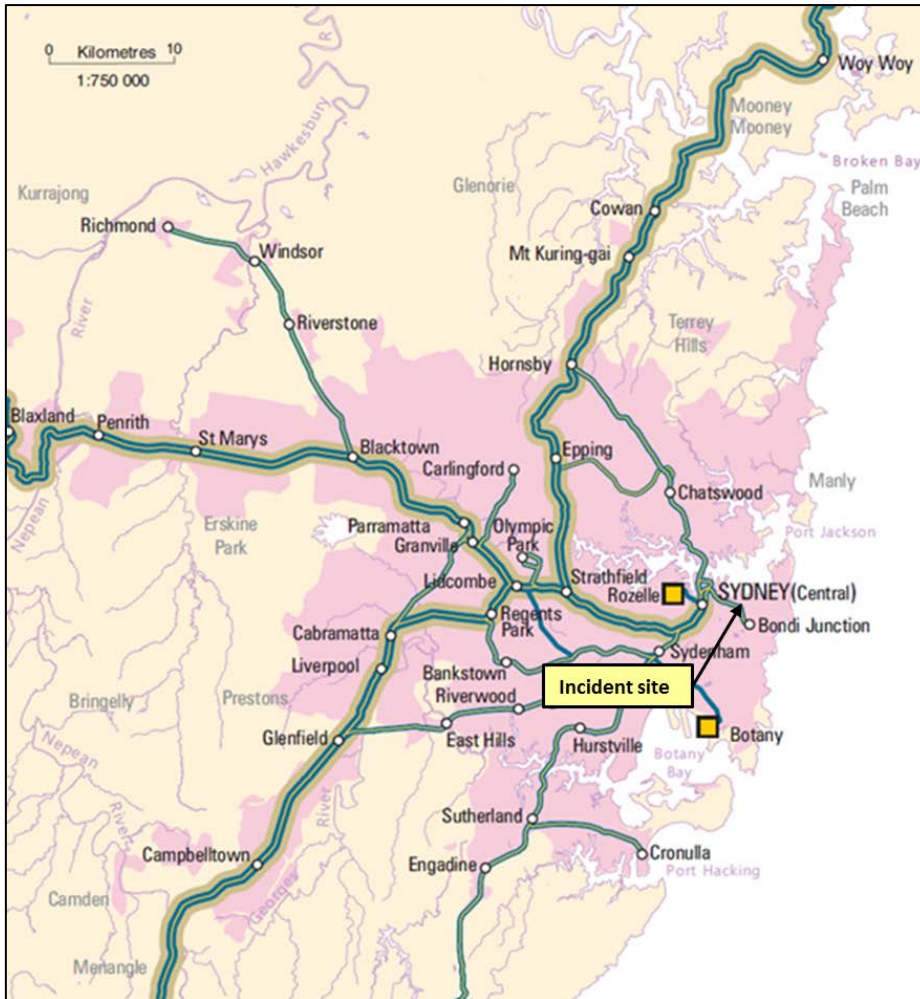

Source: Geoscience Australia with annotations by OTSI

Eastern Suburbs Railway (ESR)

The Eastern Suburbs Railway (ESR) was opened in 1979 and connected the Illawarra line near Erskineville, about 2.75 km south of Central, to Bondi Junction, 6.8 km by rail from Central (Figure 7) a total of 9.55 km. The first 5.4 km including Redfern, Central, Town Hall and Martin Place stations, was constructed in underground tunnels. To the east of Martin Place, the line emerged and passed onto Woolloomooloo viaduct before again going underground to Kings Cross Station. The track then emerged onto another viaduct, Rushcutters Bay viaduct, before entering a tunnel once more on approach to Edgecliff. The rest of the track to Bondi Junction was also underground with the exception of a short stretch at the unused station of Woollahra.

Figure 7: Eastern Suburbs Rail line diagram

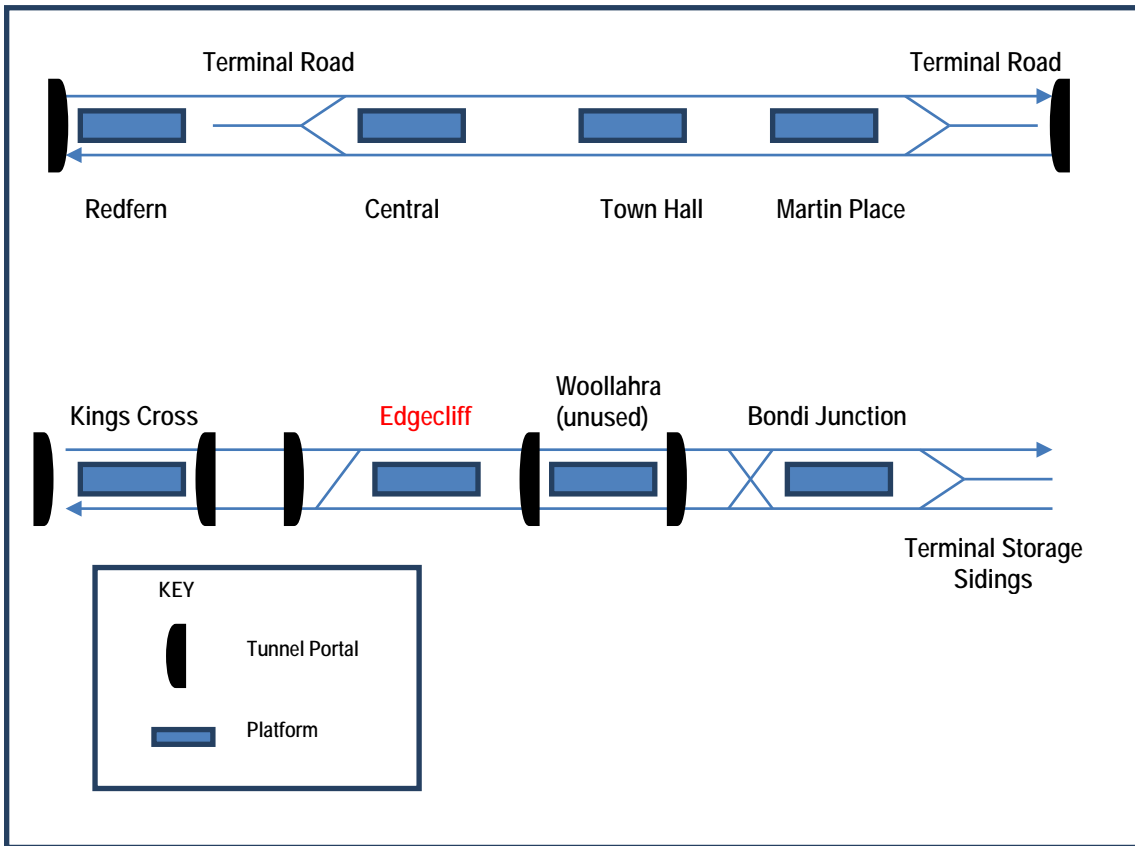

Source: OTSI

Edgecliff

Edgecliff was located about 2 km east of Sydney city centre, just under 5 km by rail from Central Station and less than 2 km from Bondi Junction. As the ESR left Edgecliff, heading towards Kings Cross, it curved to the right and exited an underground or covered section. After the line transited from under to above ground, just before Glenmore Road, it passed onto an overhead structure, Rushcutters Bay viaduct. The ESR then ran straight for about 100 m, before, still on the viaduct, curving to the left in the direction of King Cross (Figure 8).

Figure 8: Incident location

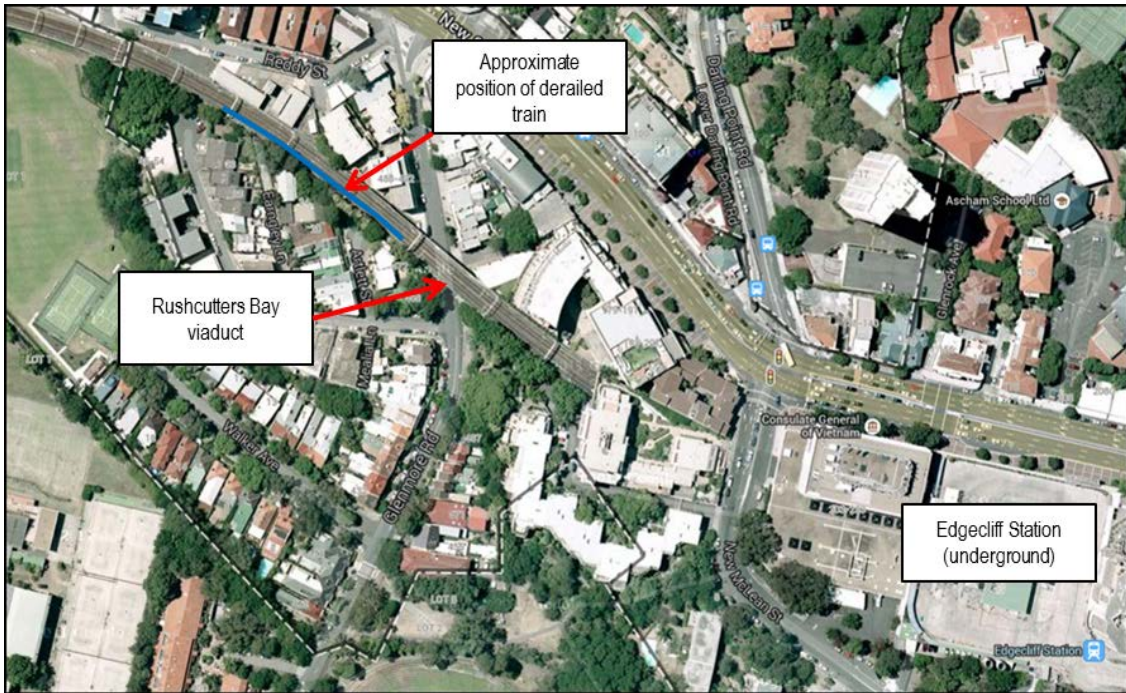

Source: Google Maps with annotations by OTSI

Organisation

Sydney Trains started operating on 1 July 2013, taking over the operation of Sydney’s metropolitan rail network from RailCorp. RailCorp in turn had taken over from the State Rail Authority (SRA). All three were NSW government owned entities.

Sydney Trains were a vertically integrated railway responsible for all aspects of Sydney Trains and NSW TrainLink rolling stock maintenance and for station staff, passenger information, train signalling, operations, infrastructure maintenance and incident management on the Metropolitan Rail Area (MRA) network. The incident occurred on the MRA network.

Sydney Trains largely kept the same operational structure that existed in RailCorp and there were no significant changes in the various roles in stations or the RMC. Similarly, the RailCorp Emergency Response Unit became the STERU and the old Network Operations Superintendent’s (NOS’) incident response responsibilities were taken over by the Incident Rail Commander (IRC). There were a total of 17 IRC’s available, in contrast to 46 suitably qualified personnel under the previous structure.

However, there was a change in the way drivers were supervised. The position of Operations Standards Manager (OSM), qualified ex-drivers who provided supervision, guidance and support to drivers, was abolished. The role of Train Crewing Shift Manager (TCSM) was substituted. This role required no rail qualification or experience and provided personnel management and supervisory functions only. TCSMs were recruited from the ranks of the OSMs, from other RailCorp positions and from outside the rail industry.

The TCSM who initially became aware of the problem at Central was an ex OSM as was the TCSM at Bondi Junction who was asked by his supervisor, the TCLO located in the RMC, to intervene.

While it is clear that both these TCSMs were acting outside their new Sydney Trains defined roles, as ex OSMs, both possessed current technical competencies. The Central TCSM who looked at the train at Central reported the matter to the TCLO. If a TCSM who was not an ex OSM had been on duty the TCLO could have asked for the train to be held while a train technician came down

from ground level. However, the TCLO stated at interview, ‘burning smell...often brakes are hot at Central as it’s all downhill from Redfern.’ He did not regard it as unusual or noteworthy. It seems likely that he would not have held the train even if a TCSM who had not been an ex OSM had been the reporter.

The TCSM at Bondi Junction was asked to get involved by the TCLO. The TCLO knew that he was another ex OSM. While the TCSM was acting outside the role parameters he was not acting outside his area of competency.

The TCLO’s own role had not changed. However, his direct reports in the field had changed from OSMs to TCSMs with the accompanying change in roles. He chose to use the ex OSM TCSMs in their old OSM role for expediency.

The TCLO was seated in close proximity to the relevant train controller and overheard him talking to the shift supervisor about reports of smoke at a subsequent station. He checked and ascertained that these reports coincided with the passage of Run 602L. However, because the report from Martin Place was of a smell like burning tyres he did not intervene to pass on information about Run 602L. The TCLO could have passed information about the train on to RMC operational staff but did not.

Infrastructure

Track

Unlike conventional track, at the point of derailment, the rails were secured to polymer concrete half sleepers which were in turn fixed to and supported by concrete slabs (Figure 9). In the Sydney Trains’ network, using either concrete or wooden half sleepers, is peculiar to parts of the ESR and Sydney underground railway.

Figure 9: View of Up track between Edgecliff and the derailed train’s location

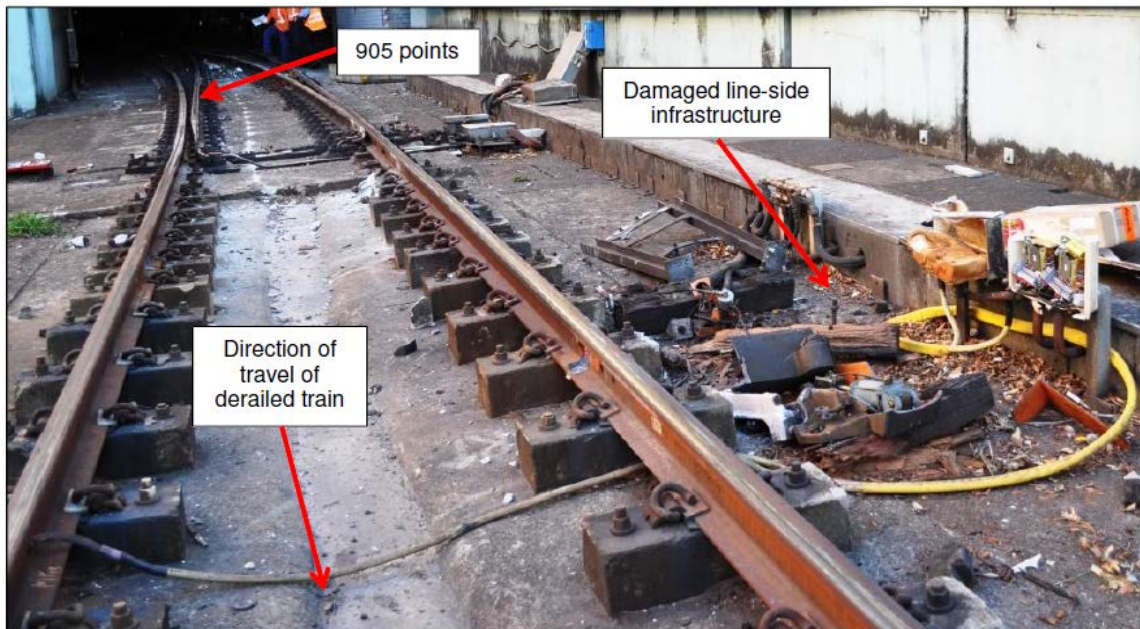

Source: OTSI

At Edgecliff, the Up ESR ran alongside platform 1 of Edgecliff station and curved to the right. After a transition, the curve was constant at a radius of 402 m and a superelevation of 65 mm. At the derailment site there was a known wide gauge of 27.5 mm. That is, the distance between the rails was 1462.5 mm rather than the standard gauge of 1435 mm. No other defects were noted.

About 35 m beyond the platform there was a concrete pad to allow road / rail maintenance vehicles to be placed on or removed from track. For some of its 22 m length, the pad had lengths

of steel angle section affixed to its edge, parallel to the rail, to protect the concrete. The section was manufactured from steel 6 mm x 55 mm. The length that 602M picked up was 8.3 m long. A further 25 m after the pad, the Up ESR was joined by a crossover from the Down ESR provided to allow trains to terminate and turn back from platform 2. The points (905 points) where the crossover joined the Up ESR were trailing points, that is they allowed two routes to merge into one towards Kings Cross station. At this point the ESR emerged from the underground section and transitioned onto Rushcutters Bay viaduct.

Overhead traction system

The ESR was provided with structures supporting overhead wiring which was supplied with electricity at 1500 V DC to power trains. This was fed to trains via contact wires and pantographs located on the roofs of the end carriages of each four carriage set.

During the derailment, the trailer carriages (on which the pantographs were mounted) were not affected and there was no damage to the overhead wiring or supporting structures. The power remained on which provided continuous air conditioning within the train.

Site observations

OTSI Investigators deployed to the site after the incident, arriving at about 1900: all passengers had been evacuated by this time. It was found that the train had travelled a total of 385 m from its stationary position alongside Edgecliff station. The front bogie of the third carriage in the direction of travel had derailed towards the cess. On entering the train, a length of right angle sectioned steel angle iron was found to have penetrated the floor of the vestibule above the derailed bogie. It entered the passenger area to the extent that it marked the roof of the inside of the carriage before falling back a little with its leading edge remaining above eye level within the carriage.

There was some damage to the bodywork of the third carriage (Figure 10) and line-side infrastructure consistent with the leading end of the third carriage travelling in a derailed state. The wheels of the derailed bogie were suspended above the rail infrastructure with the weight of the carriage being borne by the traction motor resting on the Up rail.

Figure 10: Coachwork damage



Source: OTSI

There were numerous and extensive areas of damage on No. 8 wheel consistent with skidding of the wheel (Figure 11). Also, some skidding on No. 8 wheel was offset, indicating that it had not been tracking normally on the rail head when the damage occurred. While the No. 7 wheel displayed some damage, including damage consistent with a derailment, the damage did not correspond in location or severity with damage evident on the other wheel.

Figure 11: Damage to No. 8 wheel



Source: OTSI

Other damage of note was to pipe-work and a pressure gauge associated with the N5222's parking brake.

The first evidence of derailment was found at 4.668 km, 17 m after the end of the platform corresponding with a 27.5 mm wide track gauge. Marking on the gauge face of the rail indicated that No. 7 wheel had slipped off the Down (right hand) rail and into the four foot between the rails (Figure 12).

Figure 12: Point of derailment

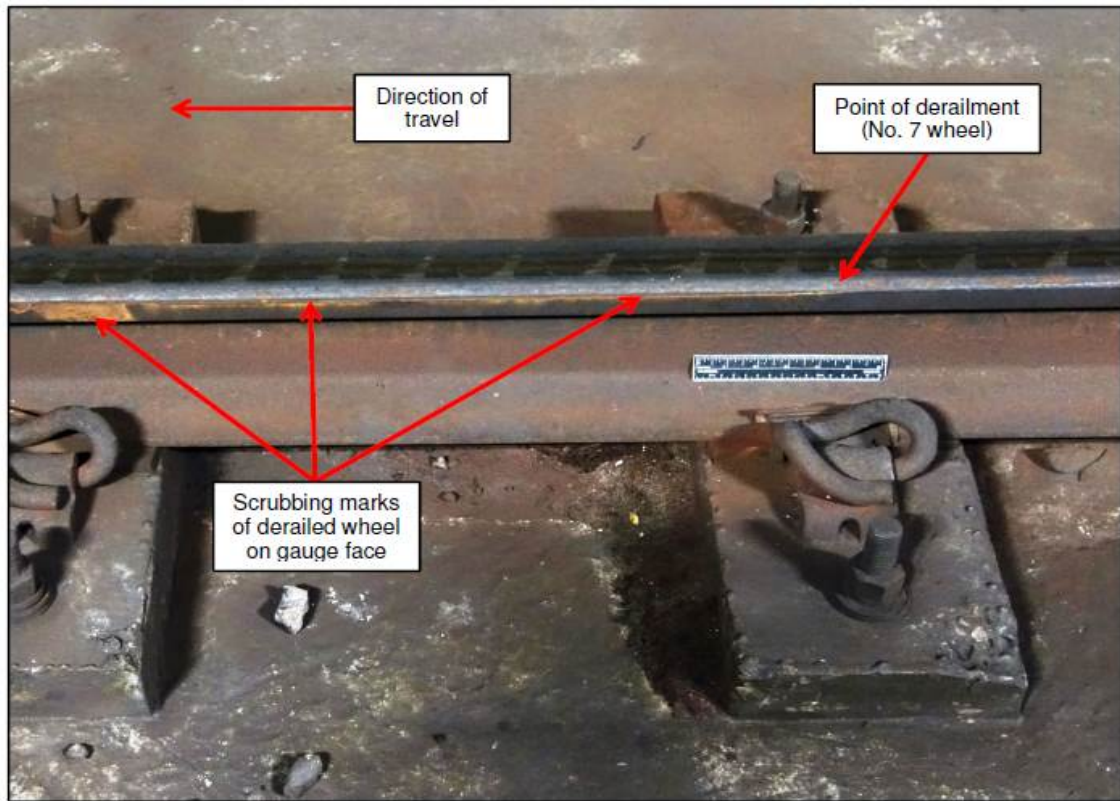

Source: OTSI

The No. 8 wheel, at the other end of the axle, remained on the Up (left hand) rail. There was further evidence of wheel No. 7 running in a derailed state in the four-foot until the concrete pad was reached. The concrete pad was significantly marked by the passage of the derailed wheel and a protecting angle iron had been broken away from the concrete and pushed towards the rail while a second piece of angle iron had been carried away. Further on at the trailing points, more significant damage was observed with further witness marks indicating that the bogie had derailed its other three wheels as it traversed this piece of infrastructure.

Rolling stock

The Tangaras were ordered from Goninan's in 1986 and entered service between 1988 and 1995. The end carriages (control trailer carriages) of each 4-carriage unit were equipped with driver compartments and had pantographs to take power from the overhead wire to supply traction motors located in the bogies of the middle two carriages (the motor carriages).

The control trailer carriages had a mass (TARE) of 42.3 t with a combined seating and standing capacity of 246 passengers. The motor carriages had a mass of 40.1 t and a combined seating and standing capacity of 276. An 8-carriage train, made up of four motor carriages and four control trailer carriages, therefore had a designed total passenger capacity of 2088 passengers. A total of 185 motor cars were built by Goninan's, plus a further 40 outer suburban Tangaras with the same axle design. This represents a total of 900 drive axles (plus spares).

Both axles on power carriages were driven through an oil bath gear box mounted on the axle. The axles had an infinite design life, that is they were expected to remain in service indefinitely without a need to replace them after a time or distance limit.

Wheel slip/slide protection

Tangaras were fitted with a pneumatic disc braking system. In normal operation they worked in an electro-pneumatic mode. Compressed air was fed to reservoirs located on each carriage which,

through an electrically controlled valve, provided air as demanded by the driver's brake control, to brake cylinders forcing brake pads onto the brake discs.

The brakes could also be used in automatic mode. This was a purely pneumatic system using air controlled valves to regulate braking. The latter system provided effective braking but required a different driving technique.

There was also a spring actuated parking (or spring) brake. A spring in this brake forced the brake on if there was no air pressure in the braking system. When a train was in service, the driver could release the parking brake by allowing compressed air to enter the parking brake's cylinder which overcame the pressure exerted by the spring thereby releasing the brakes.

To prevent wheel lock up under braking and resultant loss of braking efficiency and damage (flat spots) to wheel treads, an electronically controlled WSP system monitored all axles adjusting braking effort as required to maximise braking effort while preventing wheels from locking up and sliding along the rail head. Conversely, through the same monitoring function, the system controlled traction power to prevent wheel slip and to maximise acceleration. An indicator light was provided on the driver's dashboard which illuminated when the wheel slip/slide protection was operating (Figure 13). It was a common occurrence for the light to flash, especially during braking or power application on wet or greasy rails as traction was momentarily lost on one or more axles. However, if the light stayed illuminated for longer periods, or stayed on permanently, then the driver was required to report the occurrence and take steps to determine the cause.

Figure 13: Tangara driver control panel



Source: OTSI

As axles were of a solid construction, there was only one monitoring device per axle. In the unlikely event of an axle breaking, as occurred on run 602, the monitor would only react to one portion of the axle. Even if the other half was seized, the system would not create a fault or alarm. In the case of Run 602, the portion of the axle which was driven and turning more freely had the monitor positioned on it, reducing the frequency and period of warning indications.

Train Management System

Tangara rolling stock was also equipped with a Train Management System (TMS) which recorded defects and provided the driver with an in-cab display. The driver who was in charge of the train from Central to Bondi Junction, when the wheel slip / slide protection light illuminated multiple times, noted that the TMS showed a brake fault on the sixth carriage in direction of travel (N5222).

If the driver acknowledged the fault displayed in the TMS, as seems likely, then the fault would not appear on the display in the other cab. The next driver would only have been able to access this information by interrogating the TMS. The next driver was not required by the procedures to do so.

A TMS download, when performed by maintenance staff, yielded the last 100 faults. The system continually overwrote itself once 100 faults were reached with only the most recent 100 being available. The power was not removed from the traction motors of the incident bogie during recovery operations to Mortdale Maintenance Centre when the broken axle was supported by a pony bogie. The TMS continued recording faults, exceeding its capacity and overwriting the incident data which was therefore lost to the safety investigation.

Data logger

The train was fitted with a data logger. This device recorded certain parameters such as speed, brake and power applications and WSL activations. However, unlike the TMS, it only recorded WSL activations for the train as a whole and provided no information on which carriage the WSL activated. The data logger was successfully downloaded and the information analysed as part of the safety investigation. The analysis identified that the axle most likely failed between Sutherland and Jannali where the wheel slip indication light activations began to occur.

Bogie

The bogie, MKA0379, was a two-axle rigid framed bogie with traction motors mounted in the frame (Figure 14). This bogie arrangement has been used on electric passenger trains in NSW since 1972.

Figure 14: Tangara motor carriage bogie

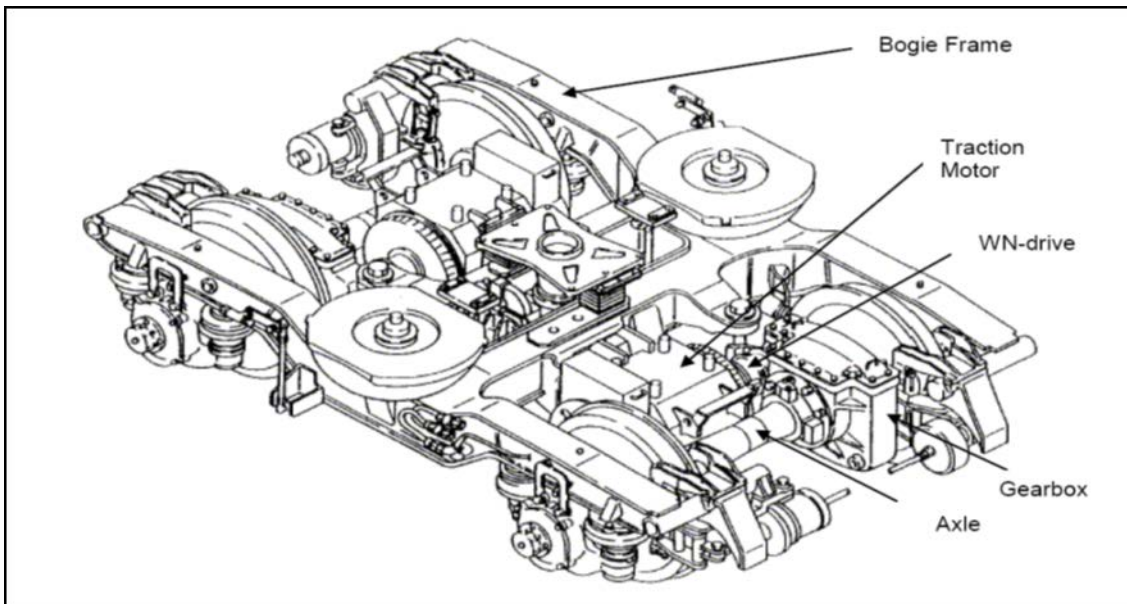

Source: Sydney Trains

Metallurgical investigation

Following the accident, bogie MKA0379 was removed from N5222 and was transported to UGL Unipart’s maintenance facility at Maintrain, Auburn. There the bogie was examined and it was noted that the gearbox casing attached to axle 881228 exhibited evidence of overheating (Figure 15).

Figure 15: Gearbox casing showing evidence of overheating

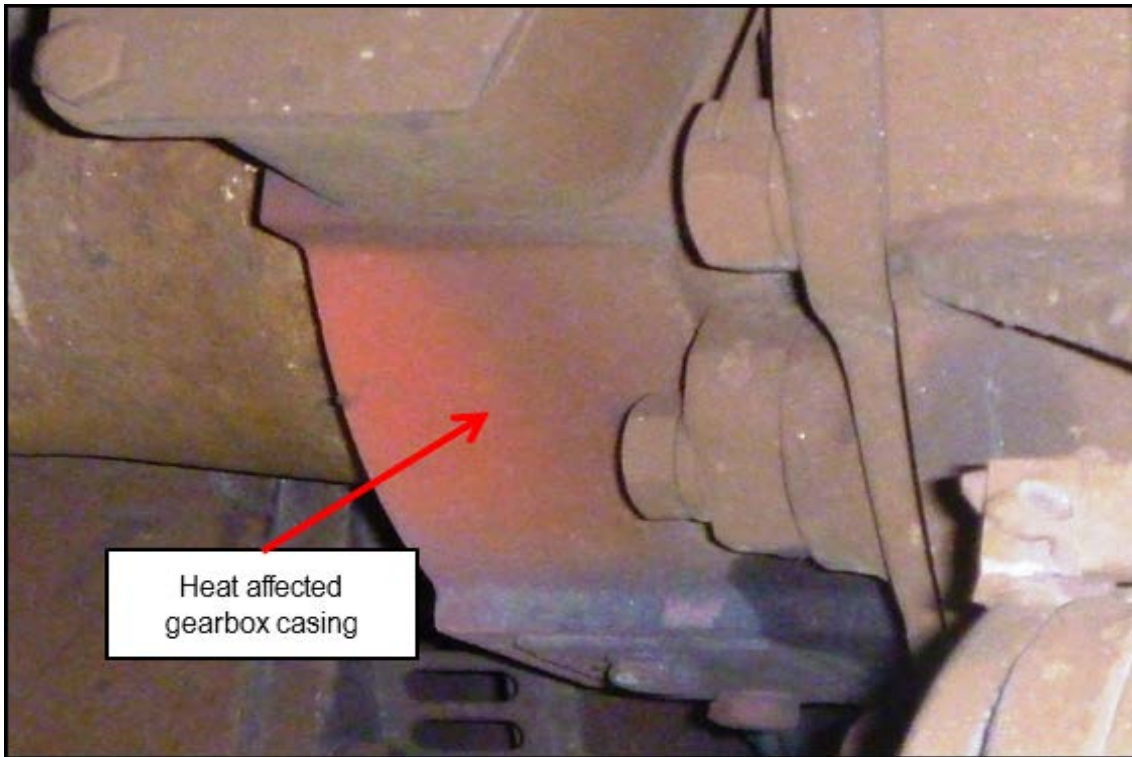

Source: OTSI

The axle, with gearbox, was removed and stripped down under the supervision of OTSI investigators. The axle was found to have broken within the gearbox between an oil flinger and a bearing (Figure 16).

Figure 16 Section of gearbox area on axle 881228

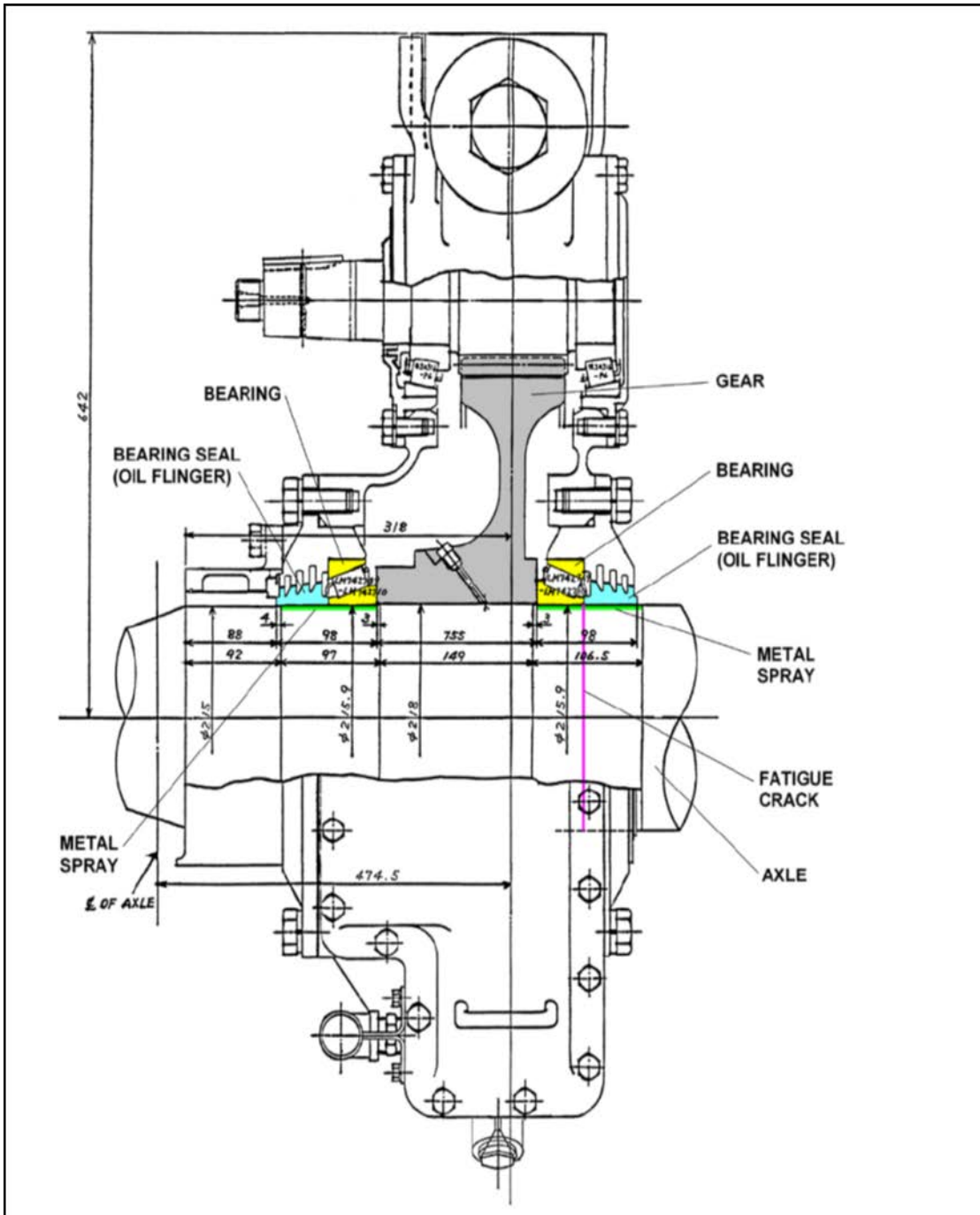

Source: Sydney Trains

Sections from either side of the defect were cut out of the axle and transported to the ATSB's laboratories in Canberra for detailed analysis. Due to their relative differential rotational speeds as they rotated against each other after the axle broke, much of the evidence of the defect initiation on the axle fracture surfaces had been destroyed. However, it was determined that a stress fracture had developed over time (see Appendix A: Technical examination of a fractured rail axle from passenger train 602M). Of particular note was the discovery of a laminated layer on the axle's surface with machining marks visible beneath (Figure 17).

Figure 17: View of axle segment showing metallic surface deposit

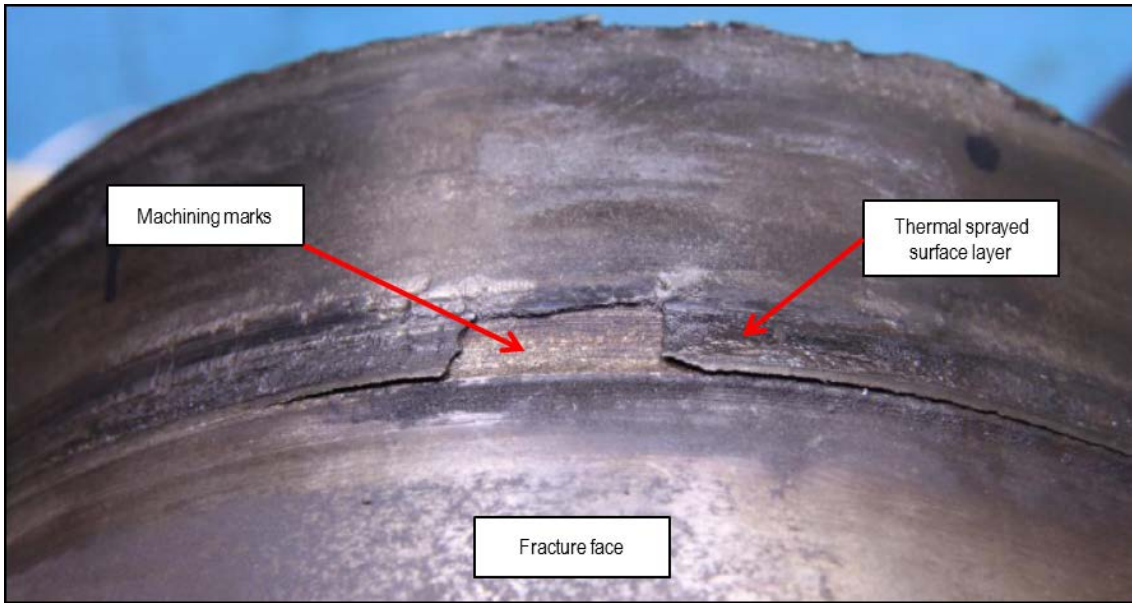

Source: ATSB

It was determined that a metal spraying process had been used to repair the axle and that this rendered the axle susceptible to the initiation of fatigue cracking.

Axle, axle maintenance, inspections and tests

The incident axle was a motor carriage driven axle. That is, it was an axle fitted through a gearbox that transferred the drive from an electric motor to the driving wheels. It was manufactured in 1988 and went into service in July of that year.

The axle’s last overhaul was performed between 6 September 2011 and 12 March 2012. Ultrasonic Testing (UT) was performed with the low speed gear wheel in place. On this occasion, a defect (crack) was discovered in the gear and the oil flingers, bearings and gear were pressed off. The axle passed various dimensional and surface finish checks and magnetic particle inspection. It was then reassembled with a new gear and low speed gear box bearings. Including this occasion, the axle had been overhauled a total of eight times during its service life.

In 1998, during a routine overhaul, it was discovered that damage had been sustained to the surfaces on the axle that accepted the interference fit low speed bearings and oil flingers that were located on either side of the crown wheel. These low speed bearings supported the gearbox on the axle. On inspection, it was determined that the axle could be repaired.

Repair methods

During the routine overhaul of axles, it was sometimes found that the axle surface at the axle ends, where the bogie axle box bearings were pressed on, were undersize. This was due to the repeated pushing on and off of the bearings removing material and so compromising the interference fit of the bearings to the axle. It was an approved repair to build up the surface using Electro Chemical Metal Deposition (ECMD).

The ECMD method is an electrolytic process where new material is deposited onto the cleaned parent metal. ECMD was not generally viable if the deposition required exceeded a depth of 0.25 mm.

In the case of axle 881228 (and any others which were subsequently repaired using metal spraying), a grooved defect was likely to have been present which exceeded 0.25 mm. Thermal Metal Spraying therefore became an option as it is suitable for greater cover thicknesses.

Thermal Metal Spraying requires machining of the parent metal on a lathe such that a depth of at least 0.5 mm new material can be achieved. The machining produces a grooved surface with a pitch of between 0.25 mm and 0.35 mm and a depth of 0.5 mm. The job is then pre-heated to between 100°C and 140°C and a bonding coat (depth 0.1 to 0.15 mm) of nickel/molybdenum/aluminium alloy is applied. This is closely followed by the application of 420 grade stainless steel. Application is by using twin electric arcs to heat the wire fed material such that it can be sprayed onto the surface to be repaired (Figure 18). Build up and adhesion of the material is a mechanical rather than fusion process: the material is not heated to a molten state but, being both heated and given velocity, has the malleability and kinetic energy to flatten as it hits the repair, joining with and building up the surface progressively as the job is rotated, at approximately 80 RPM on the lathe. Once material has been built up to a depth such that the diameter is 2 mm oversize, it is ground to produce the final surface finish and specified dimension.

Figure 18: Example of metal spraying process

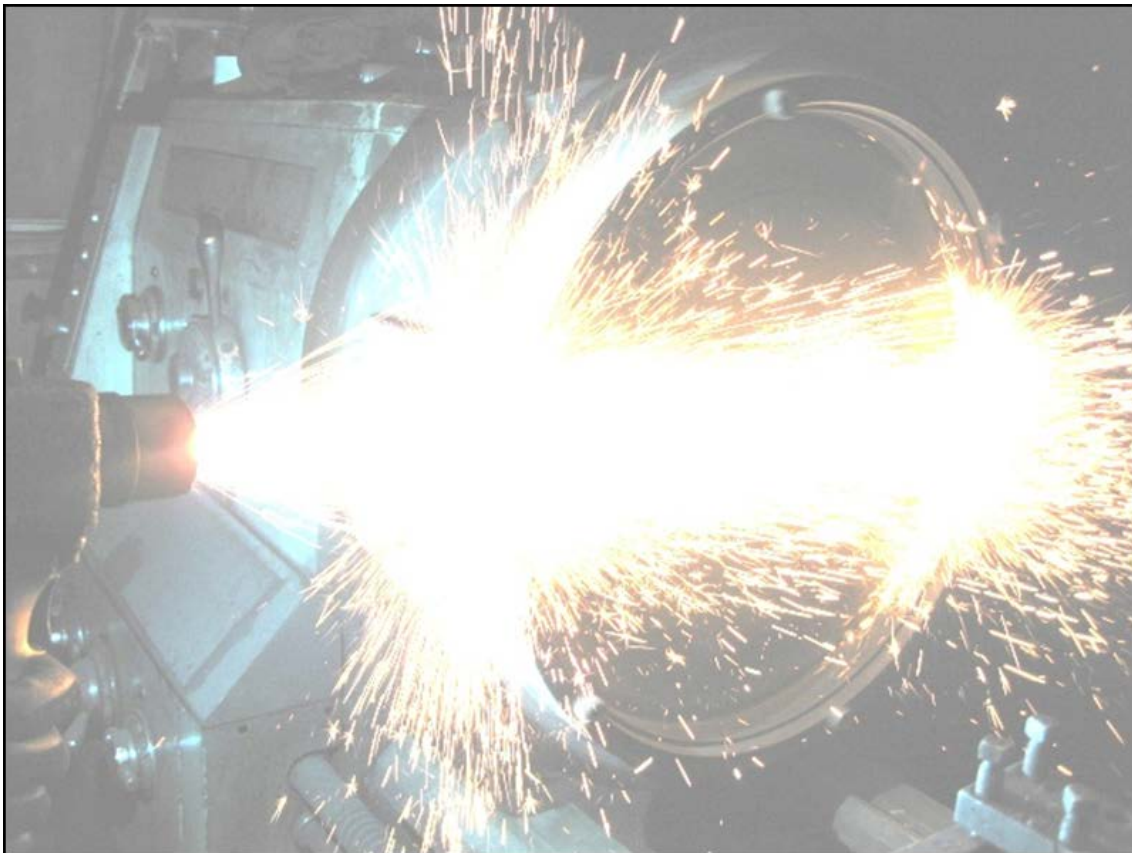

Source: A1 Metallising Services Pty Ltd

Authorisation

There was no standard repair method for this location on these axles. Authorisation for a non-standard ECMD repair was provided for by raising an Application for Deviation from Specification form (the deviation). This form, dated December 1998, was signed by the requesting engineer at Maintrain (UGL Unipart’s predecessor organisation) and approved by the State Rail Authority (SRA), a predecessor organisation to Sydney Trains. The deviation was marked as ‘Applies Indefinitely’, that is, it gave ongoing approval for further axles to be reclaimed in a like way.

However, the contractor, A1 Metallising Services Pty Ltd (A1 Metallising), determined that a repair could not be carried out using an ECMD technique as specified in the deviation. A1 Metallising reported this was probably due to the depth of the defect. A1 Metallising quoted to repair the axle, and another one with similar damage, using a thermal metal spraying technique.

No evidence was available as to how, or if, this change was approved by Maintrain. However, A1 Metallising stated that any job would always require a written quote to be accepted by the customer before they would proceed. The final invoice, issued on 31 January 1999, identified that the axles had had the following work: ‘metallise and grind on 2 positions each (that is, on both low speed bearing / oil thrower positions, one on each side of the crown wheel)’. The invoice was therefore non-specific and did not identify the actual process applied.

Other axles

It was found, through A1 Metallising’s archive search, that a total of 7 axles were recorded as having had a metal spray repair, including axle 881228. Two had been scrapped or were in the process of being scrapped while 4 were examined for defects. No further defective axles were identified. All these axles were quarantined to ensure that they were not returned to service after the incident and will be scrapped.

Operational staff

All operational staff involved in the incident were employed by Sydney Trains. A number of operational employees had a significant part in the build up to the incident, the incident and/or the response to it.

Train drivers, including trainee and driver trainers

Five driving staff were directly involved with Run 602 during the incident sequence, plus a driver who was travelling as a passenger on the train and who assisted post incident.

The train was under the control of a trainee supervised by a driver trainer at the likely time of the axle breaking. Neither of them, nor the other driver travelling as a passenger, were aware of anything amiss nor did they observe any WSP indications en route to Central station. From Central to Bondi Junction, a single driver was in the cab. He became aware of the issues with the train when informed by the guard, between Martin Place and Kings Cross, of the reports of an odour and smoke coupled with WSP indications and a TMS fault. The driver reported this to the TCLO and requested that ‘someone check it at Bondi or somewhere’. He also instructed the guard to pass on a message regarding the train’s condition to the new driver at Bondi Junction. On arrival at Bondi Junction, the guard passed on the message to the trainee driver while the driver spoke directly to the new driver (a driver trainer) on the platform. However, apparently the message was not fully received or heard by the new driver. The driver trainer, in consultation with a TCSM, instructed his trainee to blow down the brakes and decided to continue the train in service.

Between Bondi Junction and Edgecliff the driver trainer instructed the trainee to switch from EP to automatic brakes and back again in an attempt to clear an assumed sticking brakes problem. Neither trainer nor trainee noticed anything wrong, nor did they notice any WSP warning light activity. After Edgecliff, when the train derailed, the driver trainer responded by applying emergency brakes. He stopped a train on the other (Down) line, 603L, by using emergency hand signals and then initiated an emergency call to Network Control. After speaking to the train controller, he elected to try to proceed to Kings Cross. When it became apparent that there was a serious problem with the train he immediately stopped the train once more.

Train guard

The guard of 602M had qualified in September 2013 with 12 months previous experience as a customer service assistant (CSA).

The guard was first alerted to a problem with the train by a CSA at Town Hall. He informed the driver of the problem after departure from Martin Place. Under instruction from the driver he had a look at the train at Kings Cross but could find nothing wrong (other than a smell). He passed on a message about the train to the trainee driver at Bondi Junction but took no part in the decision to continue in service. At Edgecliff he was approached by the CSA who expressed his view that the

train should not proceed. The guard, who was reportedly talking on his personal mobile phone at the time, did not act on the CSA's concerns or pass it on to the driver trainer.

In the lead-up to the incident, the guard had his work supplied mobile phone switched off, only turning it on after the derailment. After the derailment, the guard contacted the RMC SM to ask if there was anything that the RMC SM wanted him to do. The guard of service 603L that stopped adjacent to the incident train also made contact with the RMC SM by phone and was proactive in planning for the evacuation of 602M to 603L.

Train crewing shift managers

The Train Crewing Shift Manager (TCSM) is a relatively new position introduced with the inception of Sydney Trains on 1 July 2013. The TCSMs replaced the previous Operations Standards Managers (OSM). While an OSM was required to have had driving experience and to maintain safeworking qualifications, the new TCSM position has been defined more as a personnel management role. There is no requirement for train driving experience or indeed any rail experience at all. The current TCSM personnel were recruited for Sydney Trains and comprises a mix of previously employed OSMs, other ex-RailCorp employees and people recruited from outside the industry.

A TCSM, who was an ex-OSM, located at Central was the first employee to notice something amiss with Run 602L. He looked at the rear carriage of the train as it was alongside the platform. He reported the issues of smoke and burning smell to the TCLO and, on the TCLO's advice, allowed the train to proceed.

Two TCSMs were on duty at Bondi Junction. One was relatively inexperienced with no previous rail industry experience while the other had formerly been an OSM. The former had limited input into the discussions and decision making at Bondi Junction but expressed a view, after the derailment, that he was surprised that the train had continued in service. The other, experienced, TCSM had been contacted by the TCLO before 602L arrived and warned that the train might have sticking brakes. When the train did arrive, the TCSM in communication with the TCLO by phone and the driver trainer on the platform proceeded on the assumption that the train did have sticking brakes and volunteered to go with the train to Central. Under instruction from the TCLO he rode in the passenger area to be alert for any tell-tale signs of an issue, especially in carriage N5222.

The TCSM did notice what he thought was the sound of a wheel flat spot and reported this to the TCLO. On departure from Edgecliff station the TCSM entered the driver's compartment. He noticed a parking brake failure warning after the incident and reported this to the TCLO. The TCSM, closely coordinating with the TCLO, took an active part in establishing the state of the derailed train and assisting with the response.

Train crewing liaison officer

The TCLO received the initial report of a problem with 602L from the TCSM at Central station. He did not notify operational staff within the RMC nor did he notify the responsible fleet operations controller. Hence an opportunity was lost to (i) create an awareness with responsible operations staff to a train with an issue and (ii) to have the train checked by a qualified train technician (present on ground level at Central). The train technicians are under the control of fleet operations controllers.

The TCLO was seated in close proximity to the relevant train controller and overheard him talking to the shift supervisor about reports of smoke at a subsequent station. He checked and ascertained that these reports coincided with the passage of Run 602. He did mention this to the TC but, because the report from Martin Place was of a smell like burning tyres, he did not pass on any further information about Run 602.

Subsequently, the TCLO alerted the TCSM at Bondi Junction to the imminent arrival of run 602L and asked for his involvement. During this conversation he introduced the idea to the TCSM that the problem was sticking brakes. The TCSM was known by the TCLO to be experienced in fault

finding as an ex driver and OSM although this function was no longer within his remit as the TCSM's role did not include such operational involvement.

The TCLO and the TCSM remained constantly in communication, by mobile phone, for much of the time that the train was alongside the platform. The TCLO's direction of the TCSM was done without any reference to other RMC staff who had responsibilities in relation to train defect management and operational decisions. The TCLO could have passed further information about the train and/or coordinated with RMC operational staff, but did not.

RMC staff

The RMC is a purpose built control centre which, in one space, accommodates all Sydney Trains' train controllers, a shift supervisor, the shift manager (SM), fleet operations controllers (3), the TCLO, security (SCC) staff and passenger information employees. The relevant train controller (TC), TCLO and the fleet operations controller are all situated in close proximity to one another.

Three operations staff in the RMC were directly involved: the TC, the Shift Supervisor and the SM. The Illawarra TC reports, through the shift supervisor, to the SM. Staff were aware of different pieces of information about the train as it travelled to and changed direction at Bondi Junction but none had full information. The SM was unaware of there being an issue until the train was ready to depart from Bondi Junction. He then walked over to speak to the SCC supervisor within RMC and on being updated as to the extent of the problem made the decision, on operational grounds, to terminate the train. This decision came too late to prevent 602M from leaving Bondi Junction. The next station at which it could practicably be terminated (other than in an emergency) was Central, where a train technician was to meet it.

After the derailment, the SM was involved with incident response to and on the site, arranging for the IRC to make his way there and, in the IRC's absence, coordinating on site activities with the train guards. The TC and shift supervisor were closely involved in managing trains on the remaining available network to minimise passenger disruption. The SM assumed a coordination role after the incident, communicating with the guards of the trains (in the absence of an IRC).

Station staff

A number of station staff were involved. Of particular relevance was the involvement of station staff at Martin Place, Bondi Junction and Edgecliff stations.

At Martin Place, the DM was sufficiently concerned by the burning smell that he made a direct request to STERU to attend as he thought, by the nature of the smell, that there could have been something burning on the station premises. The DM did not channel the request through the RMC as required by Sydney Trains Incident Management Framework (IMF).

The CSA at Bondi Junction noted the vibration, smell and smoke from Run 602L and immediately informed his superior (the DM) via a hand-held radio. Later the CSA took action to inform all station staff of the emergency via a further radio call. He used the prefix "emergency emergency emergency" to alert staff to the seriousness of the situation. He also took the initiative to prevent a wheelchair passenger from boarding as he expected that the train was not going to depart. The DM was sufficiently alarmed by the quantity of smoke and the smell of burning to request (through the SCC) the attendance of STERU and the emergency services and to prepare for the evacuation of the station and the trains alongside the platforms. When the TCSM then told him that they were going to take the train out, the DM told the TCSM and the driver trainer that the emergency services had been called but train crewing staff made the decision for the train to continue in service.

The CSA at Edgecliff, who met the train expecting the wheelchair passenger to disembark, saw the smoke and smelt the odour emanating from the train and went straight to the guard's compartment. He expressed his concern to the guard along with his opinion that the train should not proceed and informed the DM of the situation by radio.

No station staff member at any of the locations reported the issues with the train to the network control staff as required by the IMF.

Fleet operations controllers

The fleet operations controllers manage the disposition of electric traction rolling-stock across the network and are the contact for drivers for any technical difficulties that arise. The controller who should have received the notification of the problem with run 602 was absent from his desk and the call from the driver of 602L when travelling between Kings Cross and Edgecliff on the outbound leg of the journey was taken by a second controller. This controller acknowledged the call in a conversational manner and noted down details but did not notify anyone else or take any further action. The first controller, on his return, was aware of the note, but as it appeared to be routine in nature, did not call the driver back. A train technician was detailed to meet the train on its return to Central and was subsequently sent to the derailed train at Edgecliff. The fleet operations controllers did not take any further part in the incident.

Fatigue

The investigation reviewed the fatigue scores of employees involved in the incident. Only one was identified as being of possible concern. The fleet operations controller who received the report from the driver of 602L, while the other fleet operations controller was absent, was approaching the end of a 12 hour shift. He had no scheduled breaks during the shift and had a Fatigue Score³ for the shift of 108. He returned to work the next day with a score for the shift of 118. Both scores are well above industry norms for employees who are expected to process safety critical information. However, a fatigue score is only an indicator of the possible existence of fatigue. No other supporting evidence was identified in the case of the fleet operations controller so no definitive conclusion can be drawn as to his level of fatigue.

Incident and Emergency Response Unit

The Sydney Trains Incident and Emergency Response Unit (IERU) includes the Security Communications Centre (SCC), within the RMC, STERU and IRC staff. The SCC directed the STERU before and during the incident and remained the team leader's contact in the RMC when on site.

Sydney Trains Emergency Response Unit

The STERU team has training and equipment akin to that of NSW Fire and Rescue, but with a specialised railway focus. The primary purpose of STERU is to provide a fire fighting response for Sydney Trains' stations and trains, especially in Sydney's city centre area. It falls under the control of the SCC and is a 'first responder' especially to fires or suspected thermal incidents. Depending on circumstances STERU might respond alone or it might respond alongside NSW Fire and Rescue. On arrival at the derailment site the STERU team leader coordinated with the emergency services and train crew. The team leader's plan to use emergency evacuation ladders at the ends of the trains, rather than the vertical ladders at the guards' compartment doors, was adopted. The STERU team leader obtained and fitted the ladders with his team and train crew.

Operations at Bondi Junction

During peak periods, trains arrive and depart frequently from the two platforms at Bondi Junction, platforms 1 and 2. Between 1700 and 1800 eighteen trains depart from these platforms and head

³ Fatigue Score: A bio-mathematical model known as the Fatigue Audit InterDyne is designed to predict aggregated fatigue risk over a roster. Fatigue risk is interpreted by way of a number related to fatigue risk, known as the Fatigue Index or FAID score. While the FAID Score is essentially arbitrary, benchmarking studies suggest that fatigue threshold scores of 80 or below are consistent with a safe system of work for Australian industrial operations.

towards the city centre, one train every 3 minutes 20 seconds on average. Since the introduction of this high frequency service with the new timetable in October 2013, a procedure has been introduced at this location only, known as 'step back'. This procedure provides for a relief driver to be at the Sydney end of the platform ready to take charge of the train on its arrival. The driver who brought the train into the platform cuts out his control and leaves the train while the relief driver steps into the cab at the opposite end and prepares to depart. The guard does not change. Generally there will not be the opportunity for the drivers to talk to one another as happens at every other location where the driver of a train changes while in service. Any messages for the relief driver from the original driver may be relayed through the guard.

There is a train crewing shift manager (TCSM) stationed at Bondi Junction. During peak times there are two: one is on the platform to ensure that drivers are in position on the correct platform and at the right time, the other is likely to be performing administrative duties in their office. The office is located on the platform level adjacent to a room where train crew can rest in between operating train services. The second TCSM is available to assist the first should the need arise.

Rules and Procedures

A number of rules and procedures are relevant to this incident. These include:

- NGE 206 Reporting and responding to a Condition Affecting the Network (CAN): This rule stated 'Conditions that can or do affect the safety of operations must be reported promptly to the Network Control Officer responsible for the affected portions of line'. The Network Control Officer was the area's signaller. The signaller was not informed until after 602M had derailed. All prior communications had been with various RMC personnel.
- The Incident Management Framework (IMF): The IMF provides a detailed framework in 3 parts, providing guidance on how incidents from Level 1 'Routine' through to level 4 'Emergency' are to be reported, assessed, escalated and managed. IMF part 1, section 4.3 shows that all incidents are to be reported to and managed by the train controller. This requirement was not met. The emerging incident was not reported to the train controller either promptly or directly: he received incomplete and second hand information only.
- NGE 204 Network Communication: This rule prescribes the rules for spoken communication in the Sydney Trains network. This rule states that communication must be: 'clear, brief and unambiguous' and that senders and receivers 'must start the communication with identification of the receiver first and the sender second'. In these respects, NGE204 was generally observed by exception only, with the majority of the communication being conversational.
- Train Operations Manual, Operation and Management of Electric Trains (OMET) 220 'Wheel slip Light Indications': This Sydney Trains procedure 'details the instructions to be followed when a wheel slip, locked axle or slipped pinion (gear wheel) fault occurs'. For Tangara trains, intermittent or continuous activation of the WSL could mean wheel-slip, a slipping pinion or a locked axle. For activation due to wheel-slip, no action is necessary as the on-board system will respond automatically to resolve the issue. For a slipping pinion, normally indicated by a high pitched whine, a maximum speed of 25 km/h is mandated. When a locked axle is suspected, the train should be inspected from the ground to identify the locked axle (utilising the guard to watch the suspected axle(s) as the train is moved slowly). If a locked axle is confirmed, the train may be moved to the 'nearest suitable siding' if it is safe to do so, again at a maximum 25km/h. Recurring intermittent wheel slip indications can also indicate a faulty axle speed sensor.
- Train Working Procedure (TWP) 136 'Defective Wheels': this procedure directed that 'When a wheel defect is suspected or has been detected, stop and secure the train at the first suitable location and examine the wheels'. The Procedure then has detailed guidance on how to proceed dependent on the type and severity of a defect. The procedure also

mentioned pony bogies, 'designed to enable trains with broken or bent axles.....to be moved'. There was no requirement to ensure that traction motors were cut out when using a pony bogie.

- NGE 404 Using brakes: 'If, during travel, there is abnormal application of airbrakes...the Train Crew must: bring the train to a complete stop, and...if possible, determine the cause of the application or the extent of the defect...' Beyond bringing his train to a 'complete stop', the driver of 602M did not attempt to comply with this part of NTR 404 beyond looking out of his cab.
- NGE 412 Defective running gear (including damaged wheels): In the event of wheel damage being suspected this rule directs that train crew tell the Network Control Officer and 'determine the nature and extent of the defect'. A noise indicating a possible wheel flat was detected by the TCSM between Bondi Junction and Edgecliff but no action or reporting ensued.
- RMC General Order 11/13 dated 22 January 2013 'Added Responsibilities When Incidents of Skidded Wheels or Sticking Brakes Are Reported'. This order directed that train controllers are to ensure 'that any reports of skidded wheels and / or sticking brakes are fully investigated'. This order was not complied with.

Emergency response management

Sydney Trains has an Incident Management Framework (IMF). The IMF has four classifications from Level 1 'Routine' through Level 2 'Significant' and Level 3 'Major' to Level 4 'Emergency'. Network Control staff classified the incident as a Level 3 incident.

A Level 3 incident requires that the General Manager Operations appoints an Incident Manager (IM) 'to take overall responsibility for incident response management from the Shift Manager RMC'. However, the IM's role in relation to the incident site itself is reliant on there being a 'Rail Commander' on site to take charge, coordinate with external agencies and report back through the RMC SM. A Rail Commander is: 'A person qualified as Rail Commander that has been appointed by the Shift Manager RMC to liaise with emergency services and manage the rail industry response at an incident site'.

At the time of the incident, Sydney Trains had 17 Incident Rail Commanders (IRC) who were qualified to take on the role of a Rail Commander. This contrasts with the situation prior to Sydney Trains' formation on 1 July 2013 when there were 46 positions (Network Operations Superintendents, Station Operations Superintendents and Incident Response Officers) who were qualified and designated to adopt the position of Rail Commander when required. Also on 1 July 2013, NSW Trains took over the running of Interurban and country services but this did not significantly reduce the incident response task for Sydney Trains as it was still responsible for the operation of the full extent of the network previously operated by RailCorp.

When the incident happened only two IRC were on duty in the metropolitan area. One was located on the NSW Central Coast, too far away to respond, while the other had been deployed to an incident at Glenfield. This led to a significant delay (over an hour) in the arrival of an IRC on site.

Prior to the IRC arriving on site the IMF requires an Officer in Charge (OIC) to assume the role of the IRC. The Officer in Charge (OIC) 'is responsible for first response activities and informs/liases with the Train Controller...'. The OIC is a 'default appointment' and it falls to the appropriate person on site, such as the driver or station manager to adopt the role until the IRC arrives.

Sydney Trains were asked to confirm who should have been in charge of the incident site before the IRC attended. Sydney Trains' answer was, according to the IMF, 'the train driver'. However, this view was not borne out by events on 15 January 2014, with no one being in effective control on site prior to the IRC arriving. The RMC SM communicated with the guards, the TCLO acted in

parallel through the TCSM and the signaller communicated with the drivers. The STERU team leader, who communicated with the SCC took charge of aspects of the incident, such as coordinating with the Police.

Communications

A number of lines of communication were available between RMC staff and personnel on site and also Edgecliff Station. The train controller communicated with the drivers via train radio. The RMC SM talked to the two train guards by mobile phone. The TCLO was in contact with the TCSM again by mobile phone while the SCC was in radio contact with the STERU team leader. The signaller communicated with drivers via train radio as required. Due to the multiplicity of the communications channels there was a lack of clarity in regard to directing actions on site.

At Edgecliff Station, train destination boards did not reflect the reality of the line being closed for traffic, advertising train destinations as per timetable. Station staff were not informed of the nature and extent of the problem by RMC staff but were informed by emergency services when they arrived.

Sydney Trains post incident debrief

The IMF states that, for Level 2, 3 & 4 incidents, debriefs should be held as soon as practicable afterwards. Such a debrief, termed an Operational Review, was undertaken by Sydney Trains on 24 January 2014. The review was chaired by the Signal Box Operations Manager. Of the 22 Sydney Trains employees who participated only one, the IRC, had responded to the incident site. None of the participants were involved in the incident reporting or initial response phases. While this process did produce a list of recommendations (22) for change within the organisation, it may have benefited from the inclusion of more 'front line' staff who had been involved in the incident.

The debrief identified a number of key concerns; of note were the following:

- That staff frequently failed to identify themselves (contrary to Network Rules) and that safety communication was very informal
- Multiple staff (station staff and train crew staff) made multiple calls to different staff members within the RMC: 'Too many calls were made relaying similar information with no central party linking the information'
- That there was a culture of prioritising on time running over safety and that train crew ignore particular alarms and indications.

Rail resource management / risk based training needs analysis

Sydney Trains was asked to provide details of Risk Based Training Needs Analysis (RBTNA) and corresponding training in Rail Resource Management (RRM) for their staff. RBTNA documents were supplied that related to train crew (drivers and guards). No RBTNA documents were supplied in relation to any other categories of employee.

There was also an initiative sponsored by the rail regulation agencies (at the time) of New South Wales (ITSRR) and Victoria (PTSV) which led to the Rail Safety Regulators Panel (RSRP)⁴ endorsing a comprehensive document entitled *Guidelines for Rail Resource Management* in 2007. The guidelines were intended to represent best practice at the time, being modelled on/adapted from Crew Resource Management (CRM) as successfully employed by the aviation industry.

However, neither Sydney Trains nor its predecessor RailCorp had introduced Rail Resource Management (RRM), other than in a rudimentary form to train crew. Indeed, during interviews with

⁴ RSRP: a panel including representatives from Rail Safety Regulators from all Australian States, the Northern Territory and New Zealand. With the formation of the Office of the National Rail Safety Regulator (ONRSR) in 2013 the panel was discontinued.

19 Sydney Trains employees as part of this investigation, not one (including train crew) were able to identify what RRM was. The exception to this was the RMC SM who was aware of RRM/CRM but that was due to his parallel qualification as a commercial pilot in the aviation industry.

Immediate safety actions

Once it was established that an axle had broken on N5222, a programme was immediately established, by Sydney Trains and its contractor UGL Unipart, to identify and withdraw from service all Tangara axles manufactured in the same batch of steel. However, once it was established that the issue was not of a batch related metallurgical type but a maintenance issue, this programme was discontinued.

An archival search was conducted with the active assistance of the contractor, A1 Metallising, who had repaired the axle and who still held the records. Six other axles which had been similarly repaired using a metal spraying technique were identified. All axles that were still in service or available for service were withdrawn from service and / or quarantined.

To give better guidance to drivers, the Train Operations Manual (OMET 220) has had the following note added: 'NOTE: If the wheelslip indications persist and are inconsistent with the prevailing conditions (that is dry weather, level grade) Train Crews should be vigilant for signs of a locked axle or slipped pinion and carry out the following instruction.'

Also, a network wide search for access pads such as the one at Edgecliff where a potential for lengths of angle iron to be caught up under a train was completed. Only one such location was identified, also on the ESR. The angle iron lengths have been reduced on the edge of that pad.

The Train Working Procedure (TWP) 136 *Defective wheels* has been amended directing that power is isolated on a bogie when a pony bogie is fitted.

As well as initiating two internal (track and rolling stock) technical reports and engaging the services of a metallurgist, Sydney Trains contracted an external investigator to investigate the incident in its entirety. This report suggested 15 further safety actions which included some in the areas of RRM, safety critical communications and incident reporting. The ONRSR is taking a direct interest in Sydney Trains' management of these safety actions.

A new emergency number has been installed for staff to report incidents and unsafe conditions directly to operational staff at the RMC. When the number is called, a red light flashes and an alarm sounds to announce the emergency call.

Other incidents

Searches for comparable incidents were made on the internet including Australian jurisdictions, the UK Rail Accident Investigation Bureau and the US National Transport Safety Bureau. While there have been instances of axles breaking (for example, on freight wagons and the regional, diesel powered XPT rolling stock, currently operated by NSW Trains) there were no comparable incidents of an axle failure on a passenger EMU.

However, the rail industry has many examples of incidents that have either occurred or been exacerbated due to poor communications and / or failures to follow communication protocols.

Glenbrook 1999

On 2 December 1999 a passenger train collided with the rear of the Indian Pacific near the town of Glenbrook in the Blue Mountains near Sydney. Seven passengers were killed and 51 injured. A Special Commission of Inquiry was established to examine the circumstances of the accident and make recommendations. The Final Report⁵ was issued in April 2001.

⁵ McInerney, P.A., Special Commission of Inquiry into the Glenbrook Rail Accident, Final Report, 2001.

Communications were identified as a major issue during the incident: ‘...evidence from witnesses....indicated that (communication) protocol was being ignored. The result of loose, informal or casual communication can only lead to a lack of clarity and possible misunderstandings which in turn can produce tragic consequences...’⁶

The inquiry also examined previous rail incidents and it was recorded that: ‘In the Glenbrook rail accident and the reports of eight other rail accidents which I have been asked to consider, deficiencies in communication played a significant causal role in most of these incidents.’⁷ The inquiry with Communications, Risk Analysis and Training / Competency represented the largest groupings of the 63 contributing factors identified (Figure 19) with 8 instances each.

Figure 19 Categories of contributing factors of eight incidents considered in the Glenbrook Inquiry

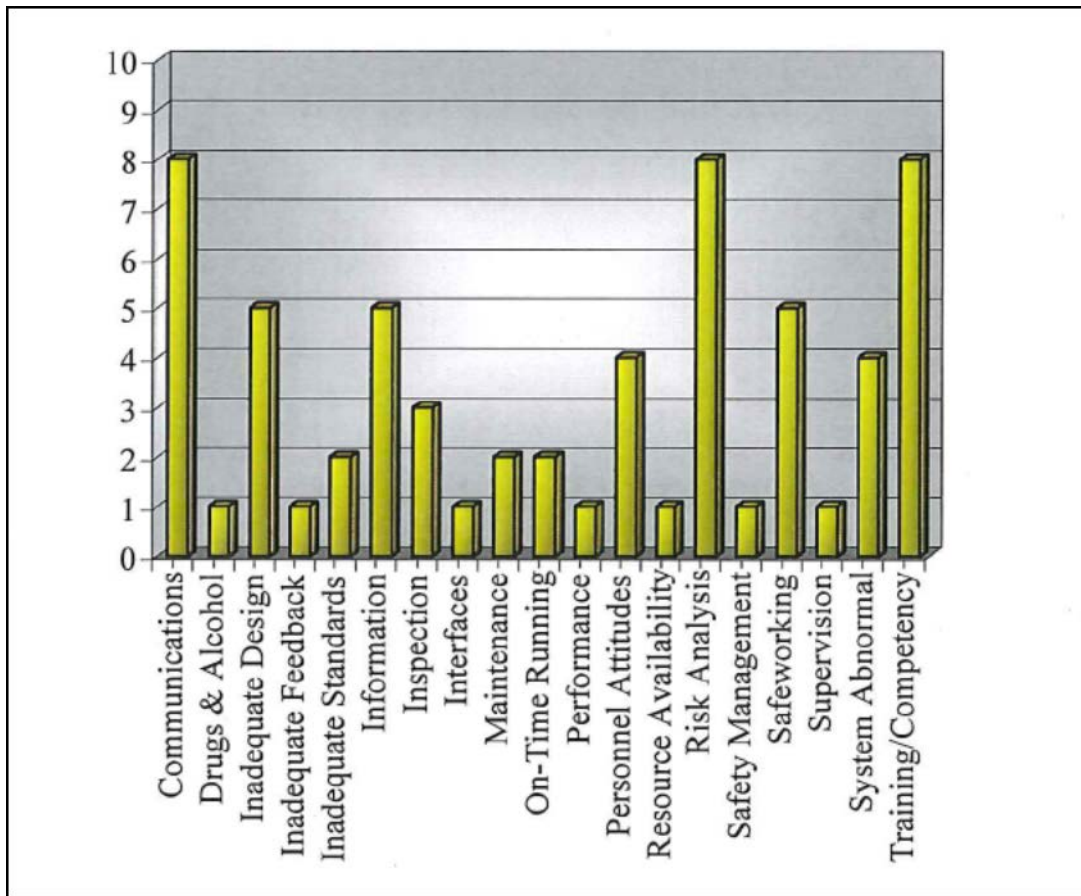

Source: Glenbrook Inquiry Final Report p107

The report made a number of wide ranging recommendations; two have particular relevance to the Edgecliff incident:

- Recommendation 2: ‘The training of railway employees should include (vi) ‘Emphasis on the importance of team work in rail operations including ensuring that operational employees have a clear understanding of the duties, roles and pressures involved in the work of other operational occupational groups.’
- Recommendation 33: ‘All communications protocols should be strictly enforced by accredited rail organisations.’

⁶ Ibid, page 141.

⁷ Ibid, page 137.

Evidence would suggest that either these recommendations were not adequately addressed in the first place or that the required standards have not been subsequently maintained.

Waterfall 2003

On 31 January 2003 a passenger train derailed on a curve at high speed and overturned near Waterfall station, south of Sydney. The driver and 6 passengers were killed while the guard and the remaining 41 passengers were injured. While communications were not identified as being causal, the Special Commission of inquiry report⁸ states on page 139: 'Although the Waterfall incident was not caused by communications failures as such, the evidence that caused concern was that there were deficiencies in the communication procedures after the incident, which could have had the effect of causing greater casualties.'

Relevant recommendations from this inquiry included:

- Recommendation 40: 'All communications related staff should be selected upon the basis of the ability to convey information clearly, accurately and concisely and to follow strict communication protocols';
- Recommendation 41: 'All communications protocols must be strictly enforced by all accredited rail organisations';
- Recommendation 68: 'Train driver and guard training should encourage teamwork and discourage authority gradients'; and
- Recommendation 83: 'RailCorp should develop a plan...to address deficiencies in the safety culture of RailCorp, including (9th item): the means whereby RailCorp proposes to ensure that communications protocols are followed by the employees of the RMC and all other employees engaged in safety critical work'.

These recommendations were tracked by the rail regulator and assessed as satisfactorily implemented by RailCorp.

A review was also undertaken of RailCorp's (and the regulator's) safety management systems and a further report was published in January 2005 as the Final Report of the Special Commission of Inquiry into the Waterfall Rail Accident Volume 2. In relation to RailCorp (and so Sydney Trains), it was concluded that there was a 'lack of an integrated SMS' (Safety Management System) and that RailCorp should 'develop and implement a human systems integration program...' including:

'Customised human factors training for rail safety workers and management/supervisory level staff based on contemporary Crew Resource Management (now referred to, in the rail industry, as Rail Resource Management [RRM]) principles'.

However, the conclusions reached by the Commission of Inquiry were not tracked and implemented as the previous recommendations had been.

Milsons Point 2007

On 14 March 2007 a train with a damaged pantograph came to a halt on the approaches to Sydney Harbour Bridge near Milsons Point during the afternoon peak period. Many passengers were left stranded on trains for up to two hours. RailCorp's investigation report concluded:

'While on site staff and RMC Train Controllers were aware of the correct incident location, other staff in the RMC were not. This situation lasted over two hours after the initial notification. Team Leaders/Supervisors within the RMC were not made aware of the exact details of the incident. There was no common understanding of the incident facts and subsequently some sections of the RMC provided incorrect information to outside areas'.

⁸ McInerney, P.A., *Special Commission of Inquiry into the Waterfall Rail Accident, Final Report*, 2005.

Parallels can be drawn between communications and coordination in this incident and the Edgecliff incident.

London Underground 2013

There was a recent incident on the London Underground (25 August 2013)⁹ which involved smoke emanating from/entering into a train in the underground. Due to poor inter-employee communications within the organisation, the opportunity to detrain the passengers and take the train out of service was missed. It continued in service and was halted half alongside a platform, half in a tunnel, after passengers raised the alarm. The incident was not properly reported and investigations only commenced when reports appeared in the media.

RAIB recommended that the operator 'review training and competencies of its staff to provide a joined-up response to incidents involving trains in platforms and to reinforce its procedures on the prompt and accurate reporting of incidents so that they may be properly investigated'.

Bondi Junction May 2014

On 14 May 2014, four months after the derailment at Edgecliff, another electric train was observed to be emitting smoke from underneath the train at Bondi Junction (once in the morning and again in the afternoon). The train was allowed to proceed on both occasions, only being checked by a train technician on arrival at Central station. The cause (a leak of compressor oil onto a hot surface) was eventually identified after the train was shut down for the night. The management of the incident and decision making processes were broadly similar to those which occurred on 15 January in relation to run 602.

⁹ Rail Accident Investigation Branch (2014) *Uncontrolled evacuation of a London Underground train at Holland Park station 25 August 2013*.

Safety analysis

The cause of the failure was a metal spraying repair carried out in the late 1990s which introduced stress initiators to the axle. Over time, stress cracking occurred and these grew to the point when, on 15 January 2014, there was no longer sufficient sound axle material to provide the necessary strength to prevent the remaining material from shearing.

The initial indications of a fault were displayed in the driver's cab through intermittent illumination of the WSL and through a fault evident from the train's TMS display. However, there were less indications of an axle problem than might have been the case due to each axle only having one wheel slip protection sensor. This sensor was located on that part of the axle which was still connected through the gearbox to the traction motor. The other section was no longer attached to the drive train and the wheel on this section exhibited multiple significant wheel skids. However, as this wheel was no longer being monitored by the wheel slip protection system, instances of this wheel locking up or running out of speed synchronisation did not generate an alarm, fault or other signal.

The differential speeds between the two parts of the axles and their relative movements as the train travelled along the track generated heat. This heat was transferred into the gearbox oil and the gearbox casing. The gearbox had a vent to atmosphere and the heated state of the gearbox oil caused fumes to be released which led to the reports of smoke and a burning smell at various locations.

At 1726 on 15 January 2014 train 602M derailed due to a broken axle, shortly after departing from Edgecliff Station. The axle had probably broken about an hour (and about 32 track km) before the incident in the vicinity of the Sydney suburban station of Jannali. This was the first recorded instance of an axle breaking Sydney Trains' EMU rolling stock. The axle broke within the gearbox such that the break could not be seen until the bogie was disassembled. The gearbox provided support for the two parts of the axle so preventing an immediate derailment.

While a broken axle of this type was outside the experience of any railway employee involved, there were a number of requirements relating to the action to be taken when the WSP activated and in regard to TMS faults, or sticking brakes or a possible seized axle. These were not followed, in a number of critical aspects, by operational staff.

The first awareness of there being an issue with Run 602 was on its arrival at Central. At and from that location and time there were a number of decision points at which the train could have been properly inspected and/or removed from service. Due to correct communication and reporting protocols not being followed, critical operational employees, notably the RMC SM, were either not informed of the issues with Run 602 or were not aware of their severity.

Once the train recommenced its journey from Bondi Junction, now travelling in the opposite direction, the axle became the leading axle on its bogie which increased the likelihood of it derailing and it did so while under acceleration at a point of wide gauge in the track on departure from Edgecliff.

Once the incident had occurred, there was no IRC available to respond to the incident in a timely manner. No Sydney Trains employee was designated as being the OIC, the point of contact for external agencies or to take charge of matters at the incident site. The STERU unit which arrived shortly after the incident had a team leader who took the initiative, in line with his role and training, to liaise with the emergency services and Sydney Trains employees on site. STERU's line of communications was to the SCC within the RMC and this was followed. Meanwhile, the RMC SM, in the absence of an IRC, decided to deal with the guards of the two trains as his best points of contact. He did not consider the STERU team leader as being a candidate to adopt the role of incident coordination until the IRC arrived. Sydney Trains have confirmed that according to their IMF in the absence of an IRC, in this case, it was the driver who should have become the point of contact (IOC) at the incident site.

The lack of a suitable appointed site coordinator (OIC) led to some delays on site, in particular in relation to the evacuation of the passengers from one train to the other. This could have been critical in a more serious incident.

Repair procedures

The repair to axle 881228 in 1998 was recognised as being non-standard. Authorisation for a non-standard repair was granted using an 'Application for Deviation from Specification' form. This deviation was requested by a Maintrain engineer due to the seating for the low speed bearings and oil flinger being 'undersize'. It is likely that the undersize issue was caused by a circumferential groove, possibly caused by the bearing casing rotating on the axle rather than a more general loss of material due to repeated pressing on and off of bearing and oil flinger parts. The authority was for a repair using the ECMD process: suitable for a small dimensional loss but not for a deeper groove type defect. However, the approved ECMD process was not the one used to repair the axle.

On inspecting the axle the repairer recognised that the damage to the axle was not suitable for an ECMD repair. The repairer stated that a written quote to repair the axle (using metal spraying) was issued to and accepted by Maintrain. While the quote document is no longer in existence and so its wording cannot be verified, the final invoice which was available to the investigation was non-specific, listing the process as 'metallise and grind'. It may have been that the quotation was equally imprecise and/or that the quotation was approved through Maintrain's normal procurement process without reference to engineering staff.

The above, though not certain after an intervening period of some 15 years, may explain how the axle, repaired using a metal spraying technique, was accepted back into service.

Non-destructive testing

Non-destructive testing (NDT) was routinely carried out on axles during periodic overhauls. One of the two methods used was ultrasonic testing (UT) whereby a probe is set at an angle to the axle's surface and an ultrasonic beam is generated which passes through the body of the axle. Any crack present in the axle, if in the path of the beam, will generate a non-standard return signal which can be observed by the operator. The last UT was conducted on axle 881228 in September 2011 and while a crack was discovered in the crown gear wheel (which was replaced) no defects were recorded for the axle itself.

The axle was also subject to magnetic particle inspection (MPI). During MPI, iron particles in suspension are coated onto the axle surface. A magnetic field is applied and, due to variations in the magnetic field caused by a surface crack, the particles congregate at the defect and so identify its presence and exact location. Neither UT nor MPI detected any defects in axle 881228 in September 2011.

While the fatigue crack had extended almost all the way through the axle diameter before axle failure, it is impossible to conclude whether or not cracking was present in the axle at the time of the last non-destructive inspection. The axle had been in operation for 22 months since that last inspection. The possibility exists that the crack was at or below the threshold of detectability at the time of the ultrasonic inspection, or that it initiated and developed after it was returned to service.

On 4 March 2014 another axle (90744), identified as having been metal sprayed at the same time as 881228, was tested for the presence of fracturing. While UT did not indicate any issues, MPI did detect what appeared to be a well-defined crack. However, no defects were found when the axle portion was examined by the ATSB's laboratories in Canberra.

It is clear that the current NDT regime used to test axles at UGL Unipart does not give a reliable indication as to the presence or otherwise of cracks in rolling stock axles.

Track condition

The track at the point of the initial derailment of No. 7 wheel had a known wide gauge of 27.5 mm. This allowed the No.7 wheel of the broken axle to derail into the area between the two rails so initiating the derailment sequence. However, reference to tables in Sydney Train's document TMC 203 Track Inspections shows that, given the prevailing speed of 60 km/h, this magnitude of wide gauge did not require an intervention such as a reduced speed limit or even the programming of a repair. Specifically, the table identified that a wide gauge of 27 - 28 mm in a track with a maximum allowable speed of 60 km/h represents a 'P3' defect. A P3 defect must be inspected within 28 days but thereafter, providing that it has been established that the defect is stable (that is, not likely to deteriorate rapidly), the specified action is to program for repair with no stipulated maximum timeframe. As the track was supported on polymer concrete half sleepers affixed to a concrete slab, a very rigid design, the likelihood of a rapid deterioration in gauge was very small. Thus, while the wide gauge triggered the derailment it could not be said to contribute. That is, it was the broken axle and not the track gauge that contributed to the derailment. The track gauge was within tolerance and the axle would most likely have derailed at some other point as the train continued towards Central.

Effectiveness of incident response

During the lead up to the derailment there were a number of opportunities when issues with Run 602 could have been identified to network control staff. These occurred from Central Station through to its departure from Edgecliff on the return journey. A decision for a train to proceed or not would generally be made by the driver or by network control staff. However, any Sydney Trains employee is empowered to prevent a train from proceeding in an emergency.

Communication procedures and communication channels are laid out in Sydney Trains' Network Rules and IMF documents. In particular, the requirement to report all conditions that can or do affect the safety of operations to the Network Control Officer was not followed. Communications channels utilised during the incident were not in conformance with the organisation's expectations (see Appendix C).

There was an opportunity at the initial point of detection, Central, to have held the train and had one of the train technicians who were present inspect the train. Had this occurred, while the train may have continued in service, it is likely that a decision to terminate it would have been made at Martin Place or at Bondi Junction. Once this opportunity was lost, until the train returned to Central, there was no possibility of a train technician attending the train as long as it remained in service.

In between Central to Bondi Junction, communications generally followed usual business channels, for example train crewing staff to train crewing staff, station staff to station staff. As the train progressed towards Bondi Junction, station staff, train crew and the fleet operations officer variously became aware of a condition affecting the train (or, in the case of the Martin Place DM, erroneously, with the station). No one contacted the signaller to initiate the Condition Affecting the Network (CAN) procedure. Key Sydney Trains employees did not use the correct channels of communication during this phase of the incident.

Consequential to the above, neither the train controller nor the RMC SM were aware of the extent of the symptoms evident on Run 602L. However, the train controller was aware of reports of sticking brakes on Run 602L and should therefore have taken action as per RMC GO 11/13 to ensure that the report was fully investigated. The General Order directs that the train controller (or the fleet operations controller) 'should (where possible) establish direct contact with the train crew'. The train controller did not attempt to contact the crew, relying on second hand information from the TCLO.

At Bondi Junction, although the original driver endeavoured to pass on both his information and his misgivings about the state of the train to the driver trainer, it appears that the information was

either not received or not fully understood. The fact that the information failed to be imparted may have been exacerbated by the coincidence of there being a trainee driver in the cab. The original driver had taken the precaution of briefing the guard to pass on information in case the drivers did not have the opportunity to converse. The guard did call the driver's cab and was answered by the trainee driver. The guard passed on reports (en route from Central to Bondi Junction) of a burning smell in or about the sixth carriage.

By this time, the TCSM, being in constant telephone conversation with the TCLO, had taken charge of the situation on the platform. The incorrect assumption that the problem was caused by sticking brakes appears to have coloured the thinking of the TCLO and through the TCSM to the driver trainer. There was also an authority gradient apparent: from the TCLO through the TCSM to the driving staff and then to the guard.

Despite the combination of heavy fumes, odour and the fact that sticking brakes were extremely rare on this class of rolling stock, sticking brakes were accepted as the cause, creating confirmation bias whereby other possibilities, such as axle, bearing or gearbox problems, were subordinated. Even the information imparted by the DM that NSW Fire and Rescue were on their way did not influence the decision for 602M to continue in service. Some employees, at interview, commented that a culture existed in Sydney Trains which emphasised the importance of keeping trains running over other considerations. There appeared to be a strong focus on 'on time running' and a 'can-do' culture rather than one focussed on adherence to safety critical procedures.

The decision to continue in service was made by the driver and TCSM on site, with advice from the TCSM in the RMC. Once the train departed, there was no strong indication that might have alerted the TCSM or the train crew to the fact that their diagnosis was incorrect although the TCSM did identify the sound of possible wheel flat-spots. However, this symptom in itself did not alter his perception of the likelihood of sticking brakes, indeed it could have tended to support it. There were also multiple WSL activations but these were not acted on by the crew. At interview, both the driver trainer and trainee stated that they had not been aware of them.

A final opportunity to avert the derailment was lost when the CSA at Edgecliff made a representation to the guard that the train should not proceed. The guard stated at interview that he only had a vague recollection of the CSA speaking to him and did not think that the CSA had asked him to stop the train.

The train's derailment manifested itself to the driver trainer as the train 'self-braking' and the WSL coming on (closely followed by the park brake light). The driver trainer took charge and brought the train to an immediate stand and initiated an emergency train radio call to Network Control. At interview the driver trainer said he thought a possible cause was a 'locked axle'. However, in his discussion with the train controller who answered the emergency call the possibility of a locked axle was only mentioned once near the beginning of the conversation (the TC stated at interview that he did not hear it) and the focus of the discussion was on a possible parking brake issue. The parking brake light was on, triggered by damage sustained during the derailment. As the train was stationary the WSL had extinguished.

The driver trainer and train controller discussed what to do next. The train controller suggested that the driver should get down from the train and inspect carriage N5222 before proceeding. In parallel, the TCLO and TCSM were discussing the situation, the TCLO also suggested that the driver trainer should inspect the train from the ground but it is not clear if the TCSM passed this advice onto the driver trainer.

The driver stated at interview that he considered a locked axle to be a 'worst case' possibility. This possibility should have been reinforced by the fact that the WSP had provided a steady warning light for 20 seconds immediately prior to the abnormal brake application. Despite the advice from the train controller and the driver trainer's earlier realisation that the train could have a seized axle, the driver trainer decided to try to move the train to the next station.

Once the train was in motion, it quickly became obvious that there was a problem and the driver trainer halted it again. It is likely that a passenger emergency alarm button was pressed during the incident (which went unnoticed by train crew) and passengers were heard banging on the driver's compartment door shouting. Emergency passenger communication buttons were located in the vestibule areas, near the side doors. The system is a function of the TMS. When the passenger emergency alarm button is pressed, an audible alarm and visual display activates in both the guard's compartment and the driver's cab. Either employee could acknowledge the call and talk to the passenger. On Tangara trains, answered calls are not diverted rather, they remain active until either answered or cancelled by train crew.

The incident was determined to be a Level 3 incident under the Sydney Trains IMF. This required the appointment of a Rail Commander on site (the IRC). However, one was not available in a suitable timescale. In the absence of an IRC, the IMF specifies that an OIC is appointed by 'default'. However, this did not occur. In the absence of an IRC or the appointment of an OIC on site, the RMC SM dealt directly with the train guards on site. While he was aware that a STERU unit (who report through the SCC) was attending, the RMC SM did not consider the STERU team leader to be a possible substitute.

The above contrasts with the STERU team leader's perception: 'The emergency services need a Rail Commander in charge (of the rail side). We do that until the IRC arrives'. The STERU team leader had responded to a senior Police Officer's request that 'someone take charge' by telling him that he was in charge.

There were three distinct communications channels in use simultaneously between the RMC and the incident site:

- The RMC SM, in the absence of an IRC, directed events through telephone conversations with the trains' guards
- The STERU team leader, reporting through the SCC, assuming that he was in charge on site and liaised with the emergency services
- The TCLO also continued to communicate with, and direct, the TCSM who was with the train. The TCLO was of the opinion that, until the IRC arrived, the TCSM was in charge for Sydney Trains.

The fracturing of the command and control function could have led to significant uncertainty, delays and misunderstandings had the incident been more serious or complex.

At no time did Sydney Trains report the incident as required by legislation. This was because the RMC SM was unable to contact the on-call officer who was responsible for reporting to external agencies.

During re-railing operations, the overhead power lines were isolated to allow the train to be jacked up in safety. However, electrical supply was restored once this had been accomplished and the train departed under its own power. The broken axle was supported on a Pony bogie. The power to the electric motors driving the axles on the incident bogie was not disconnected. There was no documented requirement for this to occur. This led to the TMS overwriting itself so erasing data that would have been valuable for investigative purposes and is also not good practice as the affected axle, supported on the pony bogie, was being driven by its traction motor. The UK Railway Group Standard GM/RT2463 contains the following passage: 'All traction power on the defective wheelset shall be isolated before fitting a wheelskate (pony bogie).' The investigation could find no equivalent instruction in an Australian context.

Training

There is no evidence to suggest that any staff member involved in the incident was anything other than correctly certified with training and competency assessments for their respective roles up to date. Notwithstanding this, performance, notably in the area of communications, was generally not

satisfactory. Communications did not conform to Sydney Trains' rules and were ineffective. Both the informal and, in some instances, casual nature of the communications and the lack of effective communication to and within the RMC were significant factors in this incident. The fact that this was not restricted to a small number of individuals indicates that the problem is organisational rather than residing with individuals.

The Office of the National Rail Safety Regulator (ONRSR) has endorsed the concept of Rail Resource Management.¹⁰

'There are a range of tools and techniques available for the rail industry to improve and manage human performance.

A key part of improving human performance is effective training of both individuals and teams. Non-technical skills training known as rail resource management (RRM) has been developed over a long period of time and has proven successful in improving performance and managing human error.'

RRM has been adopted and modified for the rail industry after its development in the aviation industry after a series of aviation safety incidents (see Appendix B). The management of Sydney Trains and, importantly its predecessor organisation RailCorp, had not taken action to introduce and foster RRM into operational areas of the organisation. To comply with a recommendation of the Waterfall Inquiry, RRM had been rolled out, as a one-off package, to drivers and guards. No consideration appears to have been made to accommodate the conclusion from the review (carried out subsequent to the Waterfall Inquiry) that RRM (or CRM as it was termed) should be incorporated into training for 'rail safety workers and management / supervisory level staff'.

Responding to wheel slip lights

It was known that the wheel slip light (WSL) on Tangara trains would flash (activate) from time to time during normal operation, the more so when wet and/or greasy rail was encountered which reduced wheel/track adhesion. These activations did not require any response from the driver as it represented normal operation of the wheel slip/slide protection system.

All the drivers who were at the train's controls from Jannali (the likely location of the axle breaking) through to the derailment were subject to WSL activations. The initial driver could not recall the light activating. The driver who took the train to Bondi Junction could not recall the light activating between Central and Martin Place. However, he responded to a significant, unexpected light activation occurrence, coupled with a TMS fault and the report from the guard. He reported the issue to the fleet operations controller. The driver trainer who took charge at Bondi Junction stated at interview that he first noticed the WSL after departing from Edgecliff. However, the data logger indicated that there were multiple activations between Bondi Junction and Edgecliff. While he and the trainee were focused on managing an assumed sticking brakes problem (transferring from EP to automatic brakes and back), the activations should have been visible. It is considered likely that the train crew who were in charge of the train from the point that the axle broke to the derailment incident were not consciously aware of the light as it routinely illuminated during normal operations.

Research into human compliance with automation has found that operator compliance with automation decreases as the false alarm rate increases, eventually reaching a cry-wolf effect where the operator (either consciously or unconsciously) ignores the automation¹¹, thus reducing or even negating its effectiveness. While the WSL is an indication, rather than an alarm, the fact

¹⁰ Office of the National Rail Safety Regulator (2015) Web page: *Rail Resource Management*. www.onrsr.com.au/safety-improvement/rail-resource-management

¹¹ Dixon, S.R. & Wickens, C.D. (2006). Automation reliability in unmanned aerial vehicle control: A reliance-compliance model of automation dependence in high workload. *Human Factors*, 48 (3) 474-486.

remained that a driver was less likely to respond to an out of course activation due to being desensitised through exposure to repeated activations.

Further information about wheel slip issues was available in the TMS where a fault would be displayed. However, the TMS is somewhat ineffective as a warning system, as it displays text but is otherwise passive.

In conclusion

The broken axle was an unusual event and it is considered unlikely that a similar incident with the same cause could occur. However, the management of the defective train from the first manifestation of the defect through to the response to the derailment revealed inadequacies in a number of areas including communications, training, command and control and culture. There was, from the initial report to the on-site management post-derailment, an inability to effectively manage the incident.

Findings

From the evidence available, the following findings are made with respect to the derailment of the train at Edgecliff on 15 January 2014. These findings should not be read as apportioning blame or liability to any particular organisation or individual.

Safety issues, or system problems, are highlighted in bold to emphasise their importance.

A safety issue is an event or condition that increases safety risk and (a) can reasonably be regarded as having the potential to adversely affect the safety of future operations, and (b) is a characteristic of an organisation or a system, rather than a characteristic of a specific individual, or characteristic of an operating environment at a specific point in time.

Contributing factors

- The axle that broke on carriage N5222 had previously been repaired using a metal spraying technique which was not approved by the State Rail Authority (a predecessor organisation of Sydney Trains). The process rendered the axle in a state whereby it was more susceptible to the initiation of surface fatigue cracking under operational loads.
- **Reporting and communications were not carried out in accordance with Sydney Trains rules and procedures, so that key employees in the Rail Management Centre received delayed and/or partial information and allowed the train to continue in service. [Safety issue]**
- Neither the driver who was in control of the train into Bondi Junction, the driver trainer who took it over, nor the guard, were proactive in their response to the defective train as required by the Train Operations Manual.
- **Drivers are desensitised to the wheel slip protection indicator light activations through its regular activation in response to momentary losses of adhesion. This, coupled with the inadequate warning provided by the TMS, may result in delayed reaction in response to activations that need driver intervention. [Safety issue]**
- **Key staff had not been trained in Rail Resource Management. [Safety issue]**

Other factors that increased risk

- The decision, by the driver trainer, to move the train after the initial incident without checking its condition was at variance with Sydney Trains' procedural rules.
- **The lack of an appointed Officer in Charge of the incident site prior to the arrival of an Incident Rail Commander led to a fragmented response with no single employee having a recognised leadership role on site. [Safety issue]**
- The advice from the Edgecliff CSA not to move the train due to safety concerns was not acted on or relayed to the driver by the guard.
- A pony bogie was used to support the damaged derailed bogie during recovery of the train but the power was not removed from the affected bogie. This caused multiple fault codes and an over-writing of incident data in the Train Management System.

Other findings

- Passenger emergency alarms were activated but were not responded to by the train crew.

- It is likely that the wide gauge triggered the derailment. However, if the wide gauge had not existed then the broken axle would have derailed subsequently, at another location, if the train continued in service.

Safety issues and actions

Where relevant, safety issues and actions will be updated on the ATSB website as information comes to hand. The initial public version of these safety issues and actions are in PDF on the ATSB website.

Depending on the level of risk of the safety issue, the extent of corrective action taken by the relevant organisation, or the desirability of directing a broad safety message to the rail industry, the ATSB may issue safety recommendations or safety advisory notices as part of the final report.

Wheel slip protection indicator light

Number:	RO-2014-001-SI_001
Issue owner:	Sydney Trains
Operation affected:	<i>Rail: Rolling stock</i>
Who it affects:	Sydney Trains

Safety issue description:

Drivers are desensitised to the wheel slip protection indicator light activations through its regular activation in response to momentary losses of adhesion. This, coupled with the inadequate warning provided by the TMS, may result in delayed reaction in response to activations that need driver intervention.

Proactive safety actions taken by: Sydney Trains

Action number: RO-2014-001-NSA-023

Sydney trains advised of the following actions:

- The generation of an awareness program for Tangara crew and RMC personnel related to the frequency and duration of wheel slip indications. The parameters of which will be determined by engineering experts.
- The Train Operations Manual (OMET 220) as applicable to Tangara trains is reassessed for effectiveness with respect to the interpretation and management of wheel slip indications.
- Support a review of relevant Tangara training and competence assurance methods, as well as fault rectification support mechanisms by HF Specialists, to determine the need for any improvements. The review will encompass;
 - o Current Tangara Driver refresher training and competence assurance – to determine whether there is appropriate focus on fault finding with issues such as sticking brakes.
 - o Documented guidance and support provided to Drivers relevant to the WSL indications and TMS alarms – to determine whether fault finding diagnostic information needs to be clarified or added to.
 - o The Mechanical Control support process – to determine if we can improve the team working and decision making between Drivers and Mechanical Control relating to Tangara train faults.
- Review the possibility of changing the TMS to provide clearer directions to reduce the likelihood of Drivers making the incorrect diagnosis of mechanical Tangara train faults. This review would be undertaken through the upcoming Tangara Technology Upgrade project, where the current TMS functions are to be provided by a replacement Train Operating System.

The Australian Transport Safety Bureau is satisfied that the above safety actions if completed and implemented, will address the identified safety issue.

Current status of the safety issue

Issue status: Safety action pending

Justification: At the time of this report release, the safety actions advised by Sydney Trains had not yet been fully implemented. The ATSB is satisfied that the actions proposed by Sydney Trains will, when completed, adequately address this safety issue.

Reporting and Verbal Communications

Number:	RO-2014-001-SI-002
Issue owner:	Sydney Trains
Operation affected:	<i>Rail: Operations control</i>
Who it affects:	Sydney Trains

Safety issue description:

Reporting and communications were not carried out in accordance with Sydney Trains rules and procedures, so that key employees in the Rail Management Centre received delayed and/or partial information and allowed the train to continue in service.

Proactive safety actions taken by: Sydney Trains

Action number: RO-2014-001-NSA-024

Sydney trains advised of the following actions:

- Commence an immediate program that insists on the use of approved methods of safety critical communication and continuously monitor the status of this program to effect compliance. This program should consolidate all existing programs to ensure the delivery of an organisation wide standard of communication.
- In conjunction with safety action (above), mandate the use of checklists for incident response and sample their use for all defined safety critical responses.
- Clarify, train and promote as necessary to all levels of the organisation the correct means of reporting emergency related communication to the Rail Management Centre.

The Australian Transport Safety Bureau is satisfied that the above safety actions if completed and implemented, will address the identified safety issue.

Current status of the safety issue

Issue status: Safety action pending

Justification: At the time of this report release, the safety actions advised by Sydney Trains had not yet been fully implemented. The ATSB is satisfied that the actions proposed by Sydney Trains will, when completed, adequately address this safety issue

Rail Resource Management

Number:	RO-2014-001-SI-003
Issue owner:	Sydney Trains
Operation affected:	<i>Rail: Operations control</i>

Who it affects:	Sydney Trains
-----------------	---------------

Safety issue description:

Key staff had not been trained in Rail Resource Management.

Proactive safety action taken by: Sydney Trains

Action number: RO-2014-001-NSA-025

Sydney trains advised of the following actions:

Assess the status of rail resource management training within the organisation and consider its introduction, ongoing promotion and monitoring within defined safety critical areas of the Sydney Trains operation to enhance decision making, teamwork and communication skills.

ATSB comment/action in response

The Australian Transport Safety Bureau considers that Sydney Trains' proactive safety action is neither sufficiently robust nor inclusive enough to give assurance that this safety issue will be adequately addressed.

ATSB safety recommendation to Sydney Trains

Action number: RO-2014-001-SR-001

Action status: released

The Australian Transport Safety Bureau recommends that Sydney Trains revisits the recommendation from the Final Report of the Special Commission of Inquiry into the Waterfall Rail Accident Volume 2 viz: *Customised human factors training for rail safety workers and management/supervisory level staff based on contemporary Crew Resource Management (now RRM) principles* and takes action to ensure that RRM training is rolled out to all employees as categorised in the recommendation and especially RMC staff, and that RRM is embedded into Sydney Trains' training and certification processes. To assist in achieving this, it may be useful to benchmark RRM/CRM training and workplace application against both comparable rail operators and also against other high risk industries (such as aviation) both nationally and internationally.

Current status of the safety issue

Issue status: Safety action pending

Justification: At the time of the report release, ATSB considers that further actions could be taken provide suitable RRM training for employees.

Incident Rail Commander Role

Number:	RO-2014-001-SI-004
Issue owner:	Sydney Trains
Operation affected:	<i>Rail: Operations control</i>
Who it affects:	Sydney Trains

Safety issue description:

The lack of an appointed Officer in Charge of the incident site prior to the arrival of an Incident Rail Commander led to a fragmented response with no single employee having a recognised leadership role on site.

Action number: RO-2014-001-NSA-026

Proactive safety action taken by: Sydney Trains

To examine the demand for sufficient incident response commanders and expeditiously act to fill any identified vacancies.

ATSB comment/action in response

The Australian Transport Safety Bureau considers that Sydney Trains' proactive safety action does not address the safety issue in its entirety. An adequate availability of IRC personnel should lessen the response time to have an IRC attend an incident site. However, the matter of not appointing an Officer in Charge until the arrival of the IRC has not been addressed.

ATSB safety recommendation to Sydney Trains

Action number: RO-2014-001-SR-002

Action status: released

The Australian Transport Safety Bureau recommends that Sydney Trains, through a revision to its Incident Management Framework, adopts the positive appointment of an Officer in Charge for Level 2, 3 & 4 incidents once they have been reported. This requirement and the functions of an Officer in Charge should be included in the training of all operational RMC staff and all positions which may be required to adopt this role.

Current status of the safety issue

Issue status: Safety action pending

Justification: At the time of the report release, ATSB considers Sydney Trains proactive safety action does not fully address the safety issue.

Additional safety action

Whether or not the ATSB identifies safety issues in the course of an investigation, relevant organisations may proactively initiate safety action in order to reduce their safety risk. The ATSB has been advised of the following proactive safety actions taken or proposed in response to this occurrence.

Sydney Trains undertook its own investigation into the incident and a report was produced which included 19 "safety actions and recommendations":

1. The generation of an awareness program for Tangara crew and RMC personnel related to the frequency and duration of wheel slip indications. The parameters of which will be determined by engineering experts.

Status: This program will commence when the outcome of the engineering investigation is concluded.

2. The Train Operations Manual (OMET 220) as applicable to Tangara trains is reassessed for effectiveness with respect to the interpretation and management of wheel slip indications.

Status: OMET has been modified to reflect this situation

3. All axles from the same heat batch have been located and are being progressively withdrawn from service.

Status: This withdrawal was initiated but concluded when the investigation became aware of an unauthorised maintenance procedure applicable to six axles only.

4. The network is assessed to determine the location(s) of any Hi-Rail Lift pads of a similar design to that impacted at Edgecliff with a view to mitigation of any associated hazardous situations.

Status: Completed.

5. Assess the status of rail resource management training within the organisation and consider its introduction, ongoing promotion and monitoring within defined safety critical areas of the Sydney Trains operation to enhance decision making, teamwork and communication skills.

6. Commence an immediate program that insists on the use of approved methods of safety critical communication and continuously monitor the status of this program to effect compliance. This program should consolidate all existing programs to ensure the delivery of an organisation wide standard of communication.

7. In conjunction with safety action 6, mandate the use of checklists for incident response and sample their use for all defined safety critical responses.

8. Examine the benefits of a simple, station specific, information and feedback sheet with Sydney Trains contact details for distribution following incidents or significant disruption occurrences.

9. Examine the demand for sufficient incident response commanders and expeditiously act to fill any identified vacancies.

10. Clarify, train and promote as necessary to all levels of the organisation the correct means of reporting emergency related communication to the Rail Management Centre.

11. Review its capacity to conduct realistic railway emergency exercises including regular rail corridor familiarisation, joint response training and interoperability with responding services.

12. Consider and subsequently transfer to the RMC, the notifications process for ONRSR and ATSB.

13. Consider the provision of a specific Quick Reference Handbook with fault finding references for placement into train crew compartments such that immediate response items are readily available to train crew.

14. Review and consider alternative methods for driver handover functions in quick turn - around sites including Bondi Junction.

15. Review its post-incident operational debriefing methods to ensure that directly involved personnel have an opportunity to provide context and contribute to continuous improvement processes.

16. Review training syllabi to ensure that the personal obligations of safety critical defined individuals related to post-incident drug and alcohol testing are provided and understood.

17. Limit the availability and contain the distribution of post incident sources of evidence to ensure that investigation activities are not compromised.

18. Review the recovery procedures provided within TWP 136 to ensure that volatile data is retained following any significant occurrence.

19. Review contingency plans and procedures that involve the use of mobile telephones operating on the Telstra telephone network in the Bondi Junction precinct.

General details

Occurrence details

Date and time:	15 January 2014 – 1726 EST	
Occurrence category:	Accident	
Primary occurrence type:	Derailment	
Location:	Edgecliff, Sydney, NSW	
	Latitude: 33° 52' 47 S	Longitude: 151° 14' 13 E

Train details

Train operator:	Sydney Trains	
Registration:	Run 602M, Tangara set T10	
Type of operation:	Passenger - Metropolitan	
Persons on board:	Crew – 3	Passengers – estimated to be up to 700
Injuries:	Crew – 0	Passengers – 0
Damage:	Substantial damage to rolling stock and some track damage	

Sources and submissions

Sources of information

The sources of information during the investigation included:

- A1 Metallising Pty Ltd
- The Office of National Rail Safety Regulation
- Sydney Trains
- UGL Unipart

References

Helmreich, R.L., Merritt, A.C., & Wilhelm, J.A. (1999) *The evolution of Crew Resource Management Training in Commercial Aviation International Journal of Aviation Psychology*, 9(1), 19-32.

McInerney, P.A., *Special Commission of Inquiry into the Glenbrook Rail Accident*, Final Report, 2001.

McInerney, P.A., *Special Commission of Inquiry into the Waterfall Rail Accident*, Final Report, 2005.

Office of the National Rail Safety Regulator (2015) Web page *Rail Resource Management*. . <www.onrsr.com.au/safety-improvement/rail-resource-management>

Rail Accident Investigation Branch (2014) Rail report *Uncontrolled evacuation of a London Underground train at Holland Park station 25 August 2013*.

Rail Safety and Standards Board Ltd (2012) Research Brief *Non-technical skills for rail: development, piloting, and evaluation of a training course*. T869 June 2102 – Update August 2012.

Rail Safety Regulators Panel (2007) *Guidelines for Rail Resource Management* .

Submissions

Under Part 4, Division 2 (Investigation Reports), Section 26 of the *Transport Safety Investigation Act 2003* (the Act), the Australian Transport Safety Bureau (ATSB) may provide a draft report, on a confidential basis, to any person whom the ATSB considers appropriate. Section 26 (1) (a) of the Act allows a person receiving a draft report to make submissions to the ATSB about the draft report.

A draft of this report was provided to:

- A1 Metallising Services PTY Ltd.
- Office of the National Rail Safety Regulator
- Sydney Trains
- Sydney Trains' staff members (16)
- UGL Unipart

Submissions were received from:

- A1 Metallising Services PTY Ltd.

- Office of the National Rail Safety Regulator
- Sydney Trains
- Sydney Trains' staff members (3)
- UGL Unipart

The submissions from these parties were reviewed and where considered appropriate, the text of the draft report was amended accordingly.

Appendices



Australian Government

Australian Transport Safety Bureau

Appendix A: Technical examination of a fractured rail axle from passenger train 602M

Edgecliff, NSW 15 January 2014

The occurrence

On 15 January 2014 at about 1720, a Sydney Trains passenger service 602M from Bondi Junction to Cronulla derailed one bogie on the third carriage while departing from Edgecliff station platform. During the derailment sequence, a large length of steel penetrated the vestibule area in the third carriage. A subsequent inspection of the derailed passenger train at the operator’s facilities revealed that the No. 4 axle of motor car N5222, had fractured prior to the derailment.

Disassembly of the bogie from the carriage at the operator’s maintenance provider’s depot revealed that the drive axle had fractured through its cross-section within the axle-mounted gearbox. The location of fracture was between the oil flinger and low speed bearing (**Figure 1**). Sections of the fractured axle were transported to the Australian Transport Safety Bureau for metallurgical examination and further analysis.

Figure 1: General arrangement of the axle and gearbox, showing the location of fracture relative to the assembly

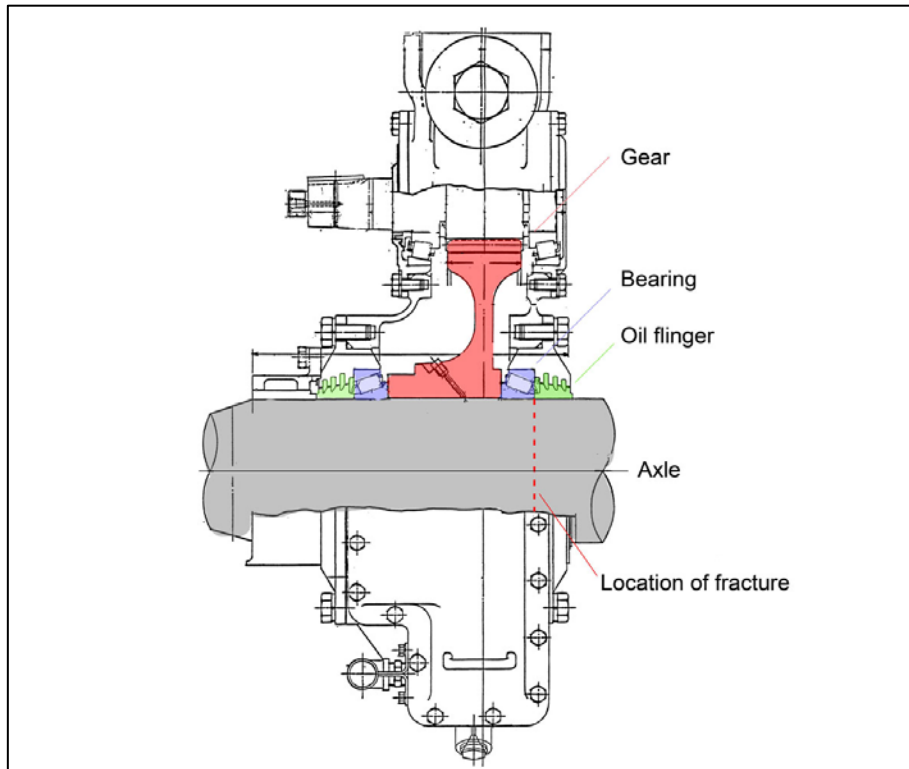

Bogie description

The Tangara motor car bogie is a rigid-frame two-axle bogie with frame mounted traction motors. A gear set connects the traction motor to the gearbox to accommodate the movement of the gearbox relative to the bogie frame as the wheelsets move with the primary suspension (**Figure 2**) at of the traction motors, gearboxes and wheelsets within the Tangara motor bogie has been used in operation since 1972; first in the double deck suburban motor cars and then in the double deck intercity motor cars from 1986.

Previous axle failures

The train operator reported that axle S/N 881228 was the first Tangara axle to have ever fractured. The ATSB is unaware of any other instances of cracking or fracture in the fleet.

Physical examination

Examination methods

Upon receipt of the fractured axle segments, the item was documented and then photographed. The oil flinger and low speed bearing were removed from the axle using abrasive cutting techniques. Both axle sections were subjected to magnetic particle, non-destructive inspection to assess for the presence of additional cracking. The axle fracture surfaces were examined at high magnification using a binocular microscope, and again at higher magnification using a scanning electron microscope (SEM). Semi-quantitative chemical analysis of the axle material was also completed using the energy dispersive spectrometer attachment to the SEM.

Upon completion of the above examination, each axle segment was destructively sectioned to obtain samples for additional metallurgical analysis. A large section of axle was submitted to an external testing laboratory for mechanical testing.

Axle Serial Number (S/N) 881228

Initial laboratory examination of the drive axle S/N 881228 established that most of the fracture surface features had been obscured by severe post-failure damage, including friction heat effects and deformation of the metal. The damage to the fracture surfaces occurred subsequent to the failure as a result of rotational contact between the mating surfaces of the broken axle. The plane of fracture was located precisely at the split line where the axle flinger and low speed bearing abutted.

It was noted that the plane of fracture was transverse to the axle axis and despite the extensive damage, a portion of the original fracture remained intact. This area was discoloured from frictional heating and showed evidence of fatigue crack progression marks (beach marks). The crack origins were not visible due to the surface deformation. The beach marks appeared to radiate from the outer surface, toward a point close to the middle of the axle, indicating that rotating bending loads were the primary driver of cracking in this instance.

The fatigue crack had propagated almost entirely through the axle cross-section, indicating that both the crack growth rate and stresses that were driving the cracking were relatively low. See **Figure 4** to **Figure 6** for photographic detail of the axle failure.

Figure 4: The fractured axle S/N 881228: low speed bearing (left axle segment) and oil flinger (right axle segment)

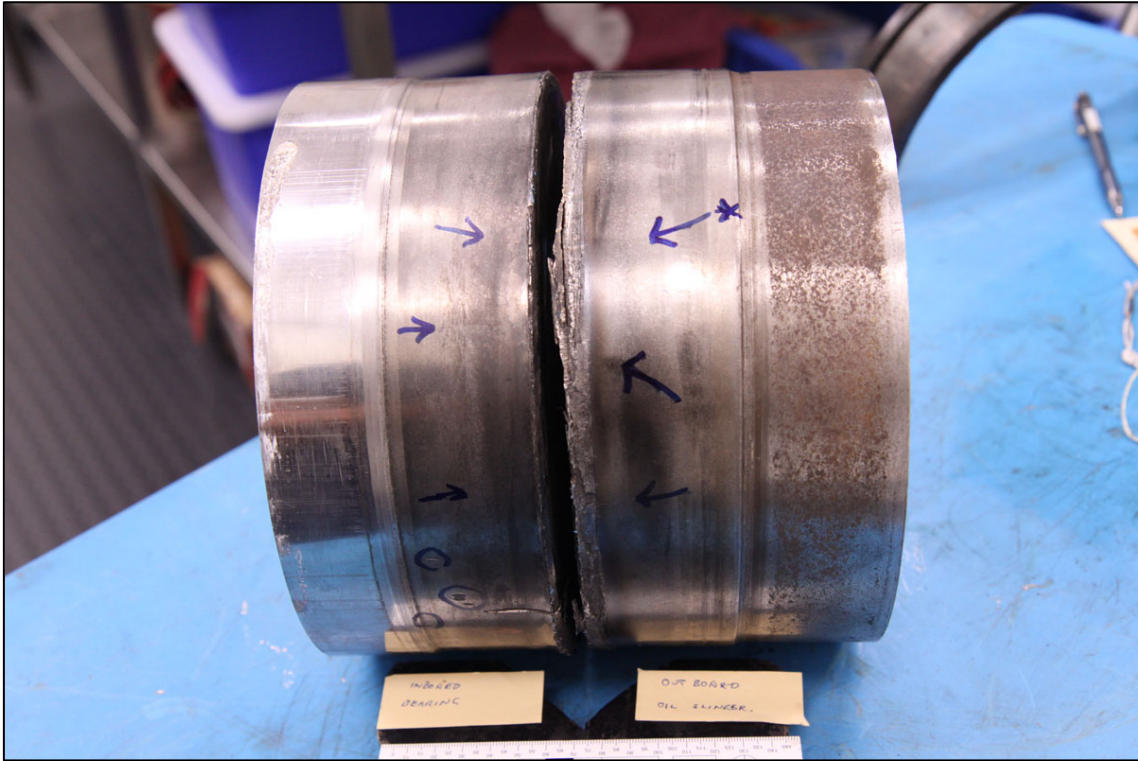

Figure 5: View of the fractured axle adjacent the oil flinger



Figure 6: View of the fractured axle adjacent the low speed bearing



Metal deposition surface repair

It was noted during the examination that a metallic layer had been deposited onto the external axle surface which extended across the location of the fatigue fracture (**Figure 7**). The layer extended around the full circumference of the axle for a length of 100 mm and had been applied over the seating area for the bearing and oil flinger. It was also observed that small sections of the metallic layer had separated from the axle which showed underlying machining marks. Such machining is typically applied during metal spray repair processes for enhancing the mechanical bond strength of the applied alloy.

A very thin bonding layer of a secondary alloy had been applied between the steel substrate of the axle and the thick metallic outer layer (**Figure 8**). Such intermediate bond layers are typically applied during thermal spray processes to enhance the adherence of the applied alloy to the substrate. The presence of the interlayer was further confirmed by a metallurgical cross-section of a segment of the axle (**Figure 9**). Measurements indicated that the metal sprayed region was around 0.70 mm to 0.80 mm in thickness. The machining marks were approximately 0.10 mm in total depth, measured peak-to-trough.

Figure 7: Close view of a metallic surface deposit that has flaked from the underlying steel axle



Figure 8: Close up of the metallic surface layer with key elements highlighted

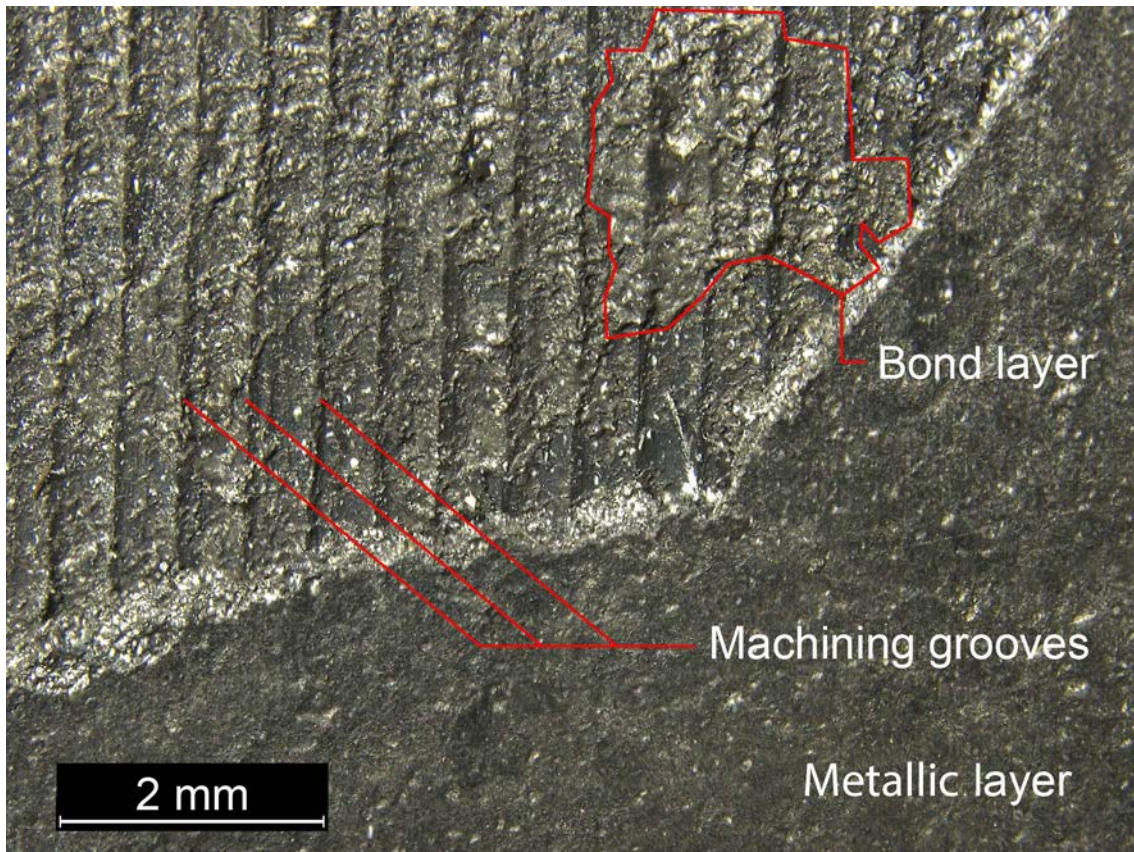

Figure 9: Metallurgical cross-section showing the applied surface layers and the steel substrate from the axle

Mechanical and chemical testing

The mechanical and chemical properties of axle S/N 881228 were tested in accordance with *Australian Standard AS 1448-2007 'Carbon steel and carbon manganese steels – Forgings (ruling section 300 mm maximum)*. This is the contemporary revision of AS G30 1971, to which the axles had been manufactured.

The document provided the minimum strength and composition limits required for the manufacture of forged and heat treated high speed rolling stock axles.

Tensile testing

Tensile specimens were prepared from the remnant axle material and then tested by an accredited mechanical testing laboratory in accordance with Australian Standard AS 1448. Three tensile specimens were machined to form and then loaded in uniaxial tension until complete failure occurred. The proof (yield) and tensile strengths of the material were recorded along with percentage elongation. Results of the testing indicated that the steel comprising each axle met, or exceeded, the mechanical property data required by the operator's specification.

Table 1 provides a summary of the mechanical property data for axle S/N 881228 when compared with the values required in the AS 1448 standard.

Table 1: Mechanical test property data for the fractured axle S/N 881228 compared with the steel specified in the standard

	Yield Stress (MPa)	Tensile Strength (MPa)	Elongation (% Area)
Australian Standard grade AS 1448 K5	270	540	NA
881228 – sample #1	326	600	24
881228 – sample #2	316	583	24
881228 – sample #3	316	583	25

Chemical testing

Semi-quantitative chemical analysis of the steel comprising the failed axle S/N 882218 was conducted using the energy dispersive spectrometer (EDS) attachment to a scanning electron microscope. The EDS analysis indicated that the axle had been manufactured using a low-carbon steel with a major alloying addition of manganese (**Table 2**). The chemical composition of the axle steel that was sampled compared well with AS 1448 K5 steel, as specified.

An EDS analysis was also conducted on the metal surface layer that was identified to have been thermally sprayed to the axle surface. The analysis confirmed that the metallic layer was primarily an iron-chromium alloy, with a much thinner intermediate bonding layer of an iron-chromium-nickel-aluminium alloy also detected (**Table 3**).

Table 2: Chemical analysis of the fractured axle compared with the specification

	Carbon	Manganese	Silicon	Sulphur	Phosphorous
Australian Standard AS 1448 K5	0.35 -0.45	0.50 – 1.00	0.10 – 0.35	0.050	0.050
Axle S/N 881228	----	0.85	0.74	0.08	0.02

Table 3: Chemical analysis of the metal sprayed surface layers

	Chromium	Iron	Nickel	Aluminium
Metallic layer	Detected	Detected	----	----
Interface bond layer	Detected	Detected	Detected	Detected

Summary of axle repair and maintenance history

Repair authorisation

The train operator indicated that Tangara axles were not typically repaired in the region of the low speed gearbox oil flinger / low speed bearing. It was often just as cost effective to condemn an axle if it became damaged beyond limits. During routine maintenance, it was sometimes found that the axle became undersized at the axle ends, along the surface where the axlebox bearings were pressed on. This was due to the repeated pushing on and off of the bearings that removed material and so compromising the interference fit of the bearings to the axle.

The authorised repair procedure for the operator’s rolling stock axles was an electro chemical metal deposition (ECMD) process that applied a homogeneous nickel-based alloy onto the axle end journal surfaces. ECMD is generally limited to repair surface damage less than 0.25 mm in thickness. Although not typically performed, the train operator had also approved ECMD as a method of repair to rebuild the axle surface surrounding the low speed gearbox.

The incident axle and another axle, S/N 90744, were the first axles to be repaired in this way. The train operator's maintenance records revealed that in 1998, both axles had been submitted for ECMD repair. In the case of axle S/N 881228, the extent of damage likely to have been present on the bearing/flinger seat area was assessed as exceeding the ECMD maximum repair depth limit of 0.25 mm. Thermal metal spraying therefore became the repair method of choice.

While the invoice documents for the work listed the use of a 'metallisation' process for the repair, no records could be located to confirm whether thermal metal spraying (as opposed to ECMD) had been specifically authorised by the operator or engineering maintenance provider.

The company that conducted the axle repair work reported that the axles were initially prepared by machining of the axle surface, followed by the spray application of an intermediate bond layer of nickel/molybdenum/aluminium, later followed with a thicker deposited layer of an iron-chromium alloy steel. The metal surface layer was applied to the axle in the region of the low speed gear seat, via a twin-arc process; the alloy was softened and then deposited in droplet form onto the axle using a high velocity gas jet (**Figure 10**).

Figure 10: Repair locations on Tangara axles – repair around the gearbox is not normally performed

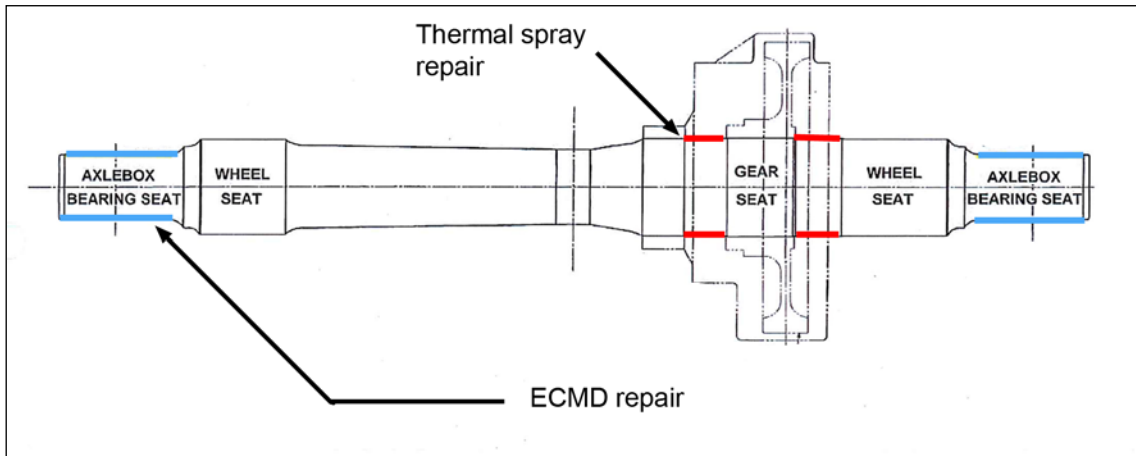

Tangara gearbox and wheelset overhauls

When a Tangara wheelset and gearbox was inducted for overhaul, a number of inspections, measurements and functional checks were conducted to assess the overall serviceability of the assembled components. The instructions for those checks were referenced in the operator's engineering procedures, *'MJI-EB25 WN Series – Reduction Gear Units, Inspect Repair and Assembly'*. The overhaul commenced with the removal of the wheels from the axle through hydraulic pressing methods.

Non-destructive inspection

The operator relied on a third-party organisation to conduct non-destructive inspection on their axles and gearboxes. To check for cracking in the axle and other serious flaws, the operator's procedures required that at overhaul, non-destructive inspection must be performed on both the axle and the gearbox. The inspections consisted of:

- ultrasonic inspection of the axles under the low speed gear area (operator's document P-3000-UT-0071)
- magnetic particle inspection on accessible areas of the axle (operator's document P-3000-MT-0032)
- dye penetrant inspection on the gear teeth (operator's document P-30000-PT-0001).

Axle crack inspection

With the gearbox remaining in place and the wheels removed from the axle, a non-destructive inspection for cracking in the axle was accomplished through magnetic particle and ultrasonic detection techniques. The operator’s magnetic particle inspection procedure required that all accessible parts of the axle be inspected for the presence of cracking and other surface defects. A surface inspection of the axle was then accomplished using an industry standard technique by the use of a magnetising handheld yoke and ferrous particles that were sprayed onto the axle surface. Any surface crack would be visually displayed as the sprayed ferrous particles concentrate around magnetic field variations.

It was not possible for the magnetic particle testing to detect for cracks in the region inboard of the gearbox housing with the gearbox remaining assembled to the axle. With the gearbox in place, the operator used an ultrasonic inspection procedure, *Gear Area Ultrasonic Examination P-3000-UT-0071* that was designed to detect for cracks under the bearings, oil flingers and the low speed gear region. The inspection was accomplished using a 45-degree angled flaw detector at a number of positions along the axle (**Figure 11**).

In order to calibrate the ultrasonic test equipment, an axle reference standard was utilized by the technicians prior to testing. The reference standard comprised a length of Tangara axle coupled with a steel sleeve (simulating the low speed gear) that had been shrink-fitted over the axle surface (**Figure 12**). Underneath the sleeve, artificial defects in the form of 2 mm deep circumferential grooves had been machined into the axle and they were used to assist in the calibration of the equipment.

Figure 11: Scanning for cracks with the gearbox in-situ: ultrasonic inspection probe scann1g positions

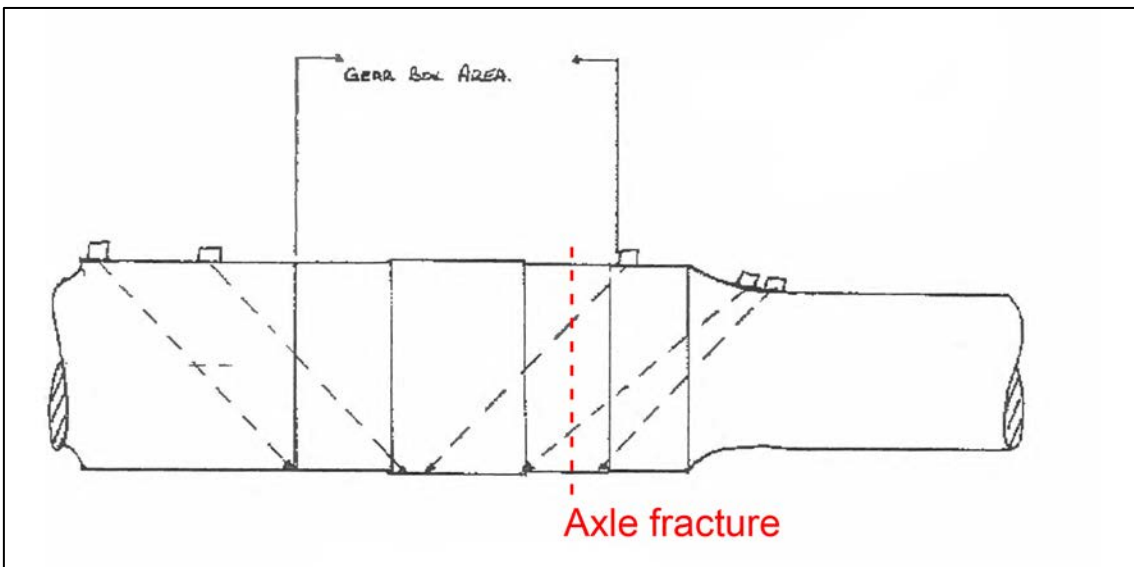

Figure 12: Tangara axle ultrasonic testing reference standard



Low speed gearbox

It was not a direct requirement to remove the gearbox from the axle during an overhaul. Removal of the gearbox was dependant on the type and size of any defects that were identified during inspection and testing. Gearbox components that were inspected as part of the overhaul included: the high- and low-speed gears, drain and filler plugs, the earth box assembly, and the gear case. The low- and high-speed bearings were functionally tested for acceptable amounts of end play. If severe defects such as pitting, fractured teeth, distortion, excessive wear, and surface cracks were identified, the gearbox was required to be overhauled.

Service and maintenance history

The operator reported that all axles are subject to a series of inspections at the time of manufacture and then again at every wheel change or heavy overhaul. A summary of the maintenance history for axle S/N 882218 was provided by the operator (**Table 4** and **Table 5**).

The last period of maintenance activity on the axle prior to the failure was conducted at the operator's maintenance provider's facilities at Auburn, NSW from 6 September 2011 to 12 March 2012. During that period, the maintenance records showed that the wheelset had been removed for heavy overhaul. The low speed reduction gearbox that was assembled with the axle was also changed during that period.

Examination of the supplied maintenance records for axle S/N 882218 showed that following the press-removal of the wheels from the axle, the axle and gearbox assembly had been subjected to a series of non-destructive inspections, consisting of:

- dye penetrant inspection on the low speed gear teeth from the gearbox
- ultrasonic inspection of the axle under the low speed gear area
- magnetic particle inspection on accessible areas of the axle.

Those inspections were signed-off as having been conducted on 21 September 2011. The test report stated that cracking was not identified during the ultrasonic and magnetic particle testing of the axle, however dye penetrant testing showed that a 'critical crack' had been found in a tooth on the low speed gear within the gearbox.

As a result of the gear tooth crack detection, the gearbox was removed from axle S/N 882218 and the low speed gear was scrapped. On 13 December 2011, the gearbox was reassembled onto the axle. New parts were fitted at that time, including low speed bearings, oil flingers and a new low speed gear. On 3 January 2012, new wheels were pressed onto the axle and on 6 January 2012 new outer bearings were fitted. All the documentation was signed off as complete. No further anomalies were noted.

Table 4: 10 year service and maintenance history of axle S/N 881228

Maintenance period	Service type
08-10-2004 to 09-11-2004	Wheel change – heavy overhaul
25-02-2005	Wheel turn
05-05-2005 to 22-06-2005	Wheel change – heavy overhaul
20-04-2006 to 10-07-2007	Wheel change – heavy overhaul
05-01-2009 to 21-03-2009	Wheel change – heavy overhaul
14-04-2011	Wheel turn
06-09-2011 to 12-03-2012	Wheel change – heavy overhaul

Table 5: Maintenance timeline for axle S/N 882218 at the last wheel change and heavy overhaul

Date	Activity
21-09-2011	Non-destructive inspection of axle and gearbox conducted
13-12-2011	New low speed gear fitted
04-01-2012	New low- and high-speed bearings installed, new low speed gear
05-01-2012	Wheels pressed onto axle
06-01-2012	New outboard bearings installed

Other repaired axles

Axle S/N 90744

The records from the company that had conducted the thermal spray repair (metallising) work on axle S/N 881228 were consulted and they showed that a total of 7 axles had been repaired using that technique. These axles have subsequently been removed from service by the operator.

Magnetic particle inspection of another Tangara axle, S/N 90744, was subsequently performed at the operator's facilities on 3 March 2013. That inspection showed a crack indication in the area that had been subjected to a metal spray repair. Subsequent destructive sectioning of axle S/N 90744 was conducted by the ATSB to assess the veracity of the indication, however no cracking was found. Five other axles were also stripped and inspected with no crack indications being detected.

Safety analysis

Axle failure

Failure of the axle Serial Number 881228 from the Tangara bogie commenced through the mechanism of fatigue cracking that eventually led to an overstress fracture of the remaining axle material. The crack was located along a journal surface within the gearbox at the abutment between the oil flinger and low speed bearing. Features on the fracture surfaces indicated that the fatigue cracking had propagated at a relatively slow rate, under low-stress cyclic conditions.

Severe post-failure metal-to-metal contact between the mating halves of the axle prevented a determination of the full extent of the fatigue cracking. Despite this lack of fine detail, it is probable that the axle was not highly stressed and that it had also been cracking for a considerable period of time during its operation. This supported by the significant penetration of the fatigue crack into the axle under nominally low stress conditions.

Axle repair

It is likely that prior to the repair being conducted, axle S/N 881228 had been damaged at some point in its service life, which then led to a decision to conduct a surface rebuilding repair. The fatigue cracking had subsequently initiated and propagated from the repaired region. Analysis confirmed that the axle had been repaired by a thermal metal spray technique using a stainless steel alloy. Although electrochemical metal deposition (ECMD) was an approved process to repair surface damage in the region of the low speed gearbox, no records could be found to indicate that the thermal metal spray repair, as found on S/N 881228, was a method that had been considered and formally approved for use by the maintenance organisation responsible for the Tangara axle overhaul process. When comparing the suitability of methods, metal spraying is used for the build-up of thicker surface layers, while ECMD is generally limited to surface repairs of less than 0.25 mm.

By virtue of their irregularly-layered morphology, thermally-sprayed metal coatings can be expected to exhibit comparatively poor fatigue crack resistance when exposed to cyclic loading regimes. When applied to the stressed surfaces of an axle, it is likely that, over time, the coating would develop micro-cracks, which would subsequently act as local stress-raisers within the substrate steel. The surface machining marks would also exhibit a similar behaviour – compounding the stress concentration effects at the axle surface beneath the coating.

As such, and in the absence of any other identified surface defects, it was concluded that the axle's fatigue endurance had been adversely affected by the use of a metal-sprayed coating as a surface rebuilding repair. This rendered the component susceptible to the initiation and growth of fatigue cracking under the dynamic stress environment associated with normal operation.

Axle inspection

The axle had accumulated approximately 22 months service following its last scheduled overhaul that was concluded in March 2012. Part of the overhaul process involved a non-destructive inspection of the axle surfaces to detect for cracks and other defects using either magnetic particle or an ultrasonic technique. The use of either method was dependant on whether the gearbox was left in place, or, disassembled from the axle. If the gearbox and low-speed gear remained assembled and in place, the operator's instructions called for an ultrasonic inspection of the axle to be used as those axle areas were not accessible when using magnetic particle inspection. The operator's records showed that an ultrasonic inspection had been conducted on the axle in the area surrounding the low speed gear and that no cracks were detected. Despite the lack of a positive crack detection using the ultrasonic technique, it remains possible that a fatigue crack was present in the axle at the time of that last inspection.

It is widely recognised that a positive crack detection while performing a non-destructive inspection is not guaranteed. Numerous factors may contribute to the reliability of a positive detection in the presence of an actual defect. Limits exist in the non-destructive method being used which leads to an industry referenced term, 'the Probability of Detection'. Factors that may influence the probability of detection include;

- the flaw being close to, or below, the threshold of detectability for the inspection method technique used
- method of inspection
- training of inspectors
- equipment being used
- accessibility
- the expectation of finding a flaw (or not)
- surface finish and geometry of the item being examined
- human factors (environmental, lighting, fatigue, work stresses, anything that may influence the ability to accurately complete the task).

Although possible, the investigation was unable to positively conclude whether cracking was present in the axle at the time of the last non-destructive inspection. Given the morphology of the fatigue crack (in the examinable areas), it is apparent that the cracking occurred under low-stress conditions through exposure to bending loads experienced during service. The axle had, however, been operated for 22 months since that last inspection. Given that extensive operational period, the possibility exists that the crack was at or below the threshold of detectability at the time of the ultrasonic inspection, or that it did not exist at that time and subsequently initiated and grew to critical (failure) size within the ensuing period.

The cracking and fracture of axle S/N 881228 is the only known failure of this type in the Tangara fleet. The potential ongoing risk to the Tangara fleet was mitigated through corrective actions from the operator by removing all axles that had been repaired through a metal spraying process in the gearbox region. For the axles in the operator's fleet identified to have been repaired using that process, it is understood that they have been removed from service, stripped down, inspected and found to be free of any crack indications.

Appendix B – Rail Resource Management

Rail resource management

Rail Resource Management (RRM) is the effective use of all available resources to achieve safe and efficient operations. The objective of contemporary Crew Resource Management (CRM) training is to enhance communication, teamwork, and threat and error management competencies. Emphasis is placed on the non-technical aspects of individual and team performance, including instruction on the limitations of human performance, the nature of error, and the mitigation and management of error. Typically RRM integration takes the form of an initial training course followed by regular recurrent training.

RRM was developed from CRM in the aviation industry:

‘The roots of Crew Resource Management training in the United States are usually traced back to a workshop, Resource Management on the Flightdeck sponsored by the National Aeronautics and Space Administration in 1979.

This conference was the outgrowth of NASA research into the causes of air transport accidents. The research presented at this meeting identified the human error aspects of the majority of air crashes as failures of interpersonal communications, decision making, and leadership.

At this meeting, the label Cockpit Resource Management (CRM) was applied to the process of training crews to reduce ‘pilot error’ by making better use of the human resources on the flightdeck. Many of the air carriers represented at this meeting left it committed to developing new training programs to enhance the interpersonal aspects of flight operations. Since that time CRM training programs have proliferated in the United States and around the world. Approaches to CRM have also evolved in the years since the NASA meeting.¹²

The principles of CRM are being applied increasingly in other industry domains with workplaces where teamwork and the management of threats and errors are vital. Examples are surgical teams, maritime organisations (bridge resource management) as well as the rail industry (as RRM):

‘Crew Resource Management, a form of NTS (non-technical Skills) training, was introduced in the aviation industry in the 1970s, and it has since spread to various other safety critical industries such as nuclear, healthcare, and shipping. In more recent years, this form of NTS training has been introduced to rail industries in Australia, USA and Canada. Evaluations of this training suggest that it can reduce safety occurrences attributable to human error.’

‘Over time, it is expected that if NTS are trained and reinforced and appropriately integrated into competence management systems, that this will result in safer behaviour and subsequently, a reduction in incidents and accidents.’¹³

Knowledge and experience about RRM built up in recent years by the use of facilitative training techniques has led to attempts to define optimum RRM performance by the use of behavioural

¹² Helmreich, R.L., Merritt, A.C., & Wilhelm, J.A. (1999) The evolution of Crew Resource Management Training in Commercial Aviation International Journal of Aviation Psychology, 9(1), 19-32.

¹³ Rail Safety and Standards Board Ltd (2012) Research Brief Non-technical skills for rail: development, piloting, and evaluation of a training course. T869 June 2102 – Update August 2012.

markers. The successful development of behavioural markers helps to define more clearly the cognitive and interpersonal skills required for good RRM and also allows for a standard approach towards assessment, feedback and further training of individual crew members. It also focuses on the development of threat and error management competencies based on the company safety culture, standard operating procedures, and organisational factors; information acquisition and processing; situation awareness; workload management; human error and reliability; communication and co-ordination; leadership and team behaviour synergy; decision making; stress and stress management; fatigue; vigilance; cultural factors; automation, and the philosophy of the use of automation.

The aim of RRM is to reduce the frequency and severity of errors for staff. It sees human error as ubiquitous, inevitable and a valuable source of information. For RRM to be accepted as a safeguard for human limitations there must be organisational recognition of the inevitability of human error. This is a recognition that organisational policies need to reflect an acknowledgement of the limitations of human performance. This does not imply that the organisations should become more tolerant of violations or accept wilful violation of their rules and procedures.

RRM focuses on the human component and RRM training must be tailored to fit the culture of the organisation. When RRM is explained with reference to the concept of human error, the goals of RRM are to:

- reduce the likelihood of error;
- trap errors before they have an operational effect;
- communicate the nature of errors;
- demonstrate the negative effects of fatigue, work overload and emergencies, and;
- mitigate the consequences of error.

These techniques include cross-checking and verification of communication, preparation, planning and vigilance, speaking up to express concerns and sharing a mental model of the situation. Correct application reduces the likelihood of an error occurring or trapping an error before it has operational impact. These techniques along with effective group decision making, and the recognition that they are not immune from the effects of stress, can equip employees to react effectively to those errors which may threaten the safety of operations.

Appendix C – Main communications channels

The first diagram below shows the main communications channels used by various Sydney Trains employees during the incident. It is complex and does not follow documented procedures.

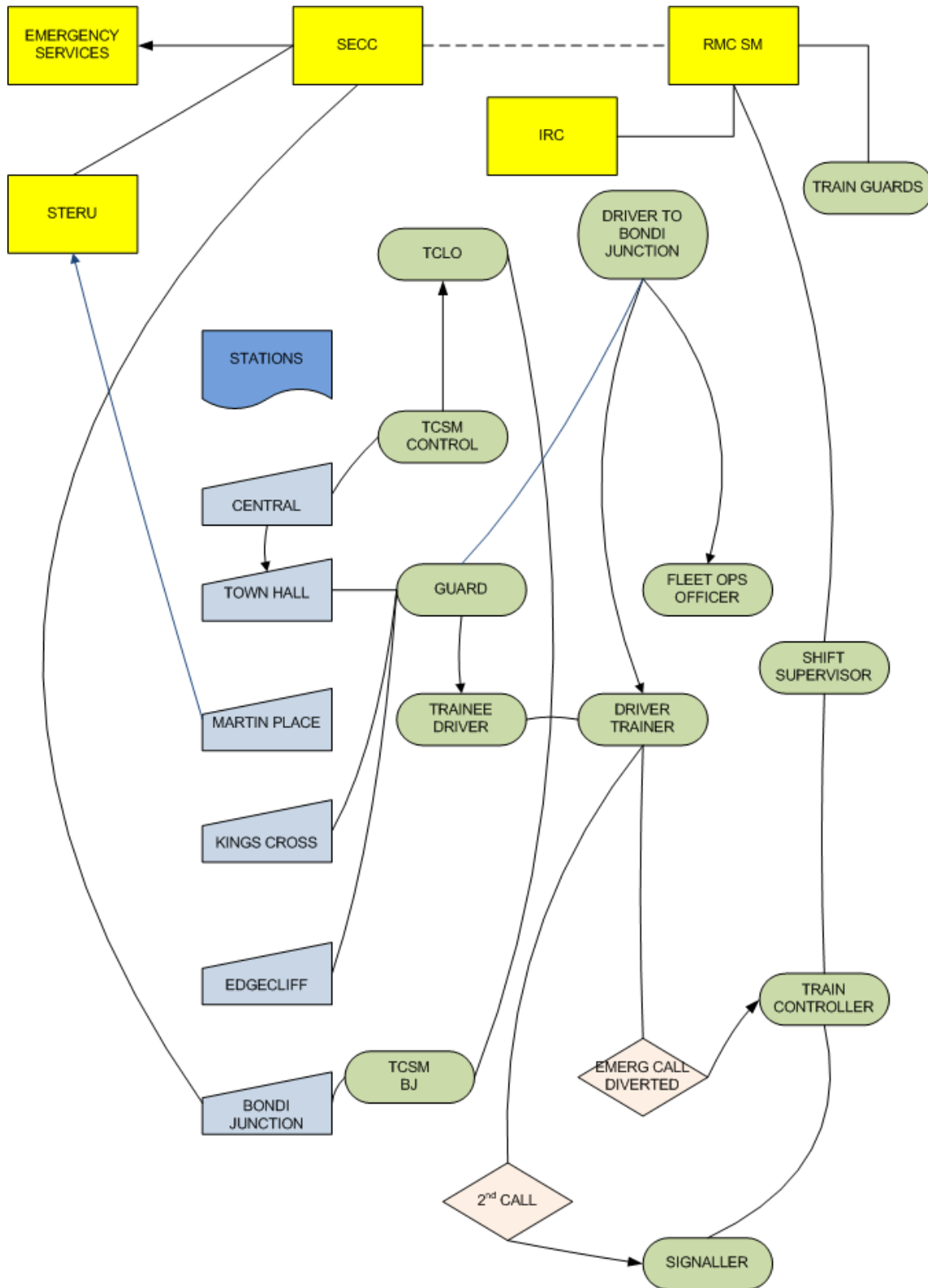

The second diagram below is less complex and represents communications channels that should have been utilised.

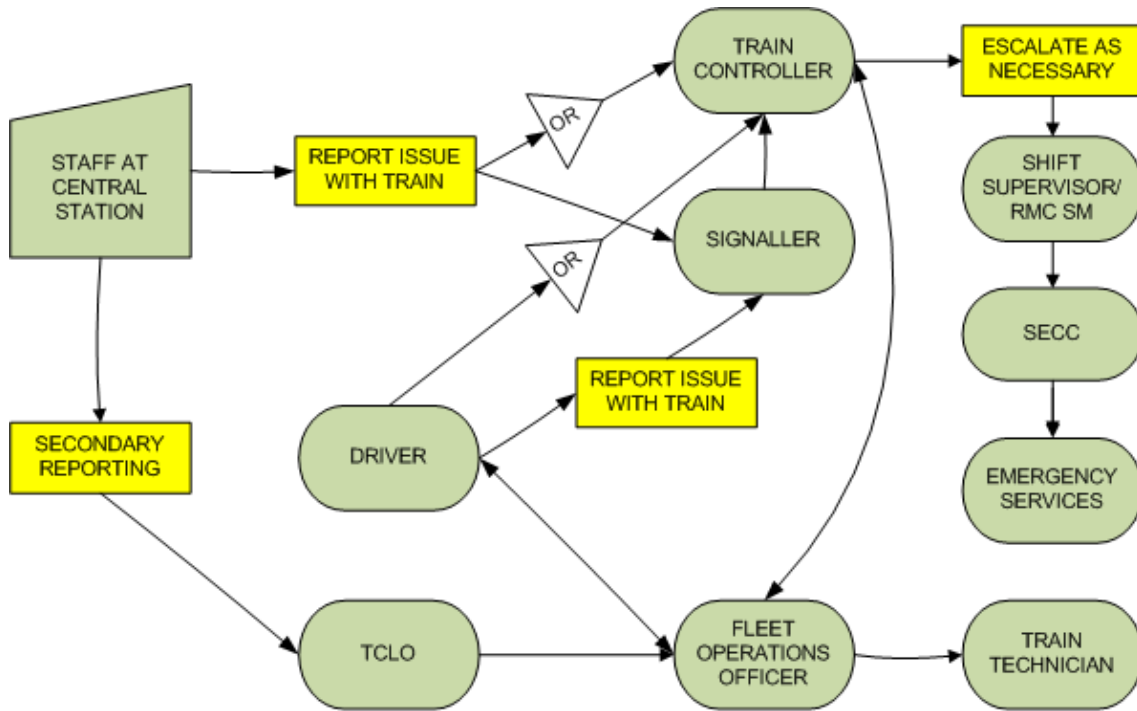

REPORTING CHANNELS

Australian Transport Safety Bureau

The Australian Transport Safety Bureau (ATSB) is an independent Commonwealth Government statutory agency. The ATSB is governed by a Commission and is entirely separate from transport regulators, policy makers and service providers. The ATSB's function is to improve safety and public confidence in the aviation, marine and rail modes of transport through excellence in: independent investigation of transport accidents and other safety occurrences; safety data recording, analysis and research; fostering safety awareness, knowledge and action.

The ATSB is responsible for investigating accidents and other transport safety matters involving civil aviation, marine and rail operations in Australia that fall within Commonwealth jurisdiction, as well as participating in overseas investigations involving Australian registered aircraft and ships. A primary concern is the safety of commercial transport, with particular regard to fare-paying passenger operations.

The ATSB performs its functions in accordance with the provisions of the *Transport Safety Investigation Act 2003* and Regulations and, where applicable, relevant international agreements.

Purpose of safety investigations

The object of a safety investigation is to identify and reduce safety-related risk. ATSB investigations determine and communicate the factors related to the transport safety matter being investigated.

It is not a function of the ATSB to apportion blame or determine liability. At the same time, an investigation report must include factual material of sufficient weight to support the analysis and findings. At all times the ATSB endeavours to balance the use of material that could imply adverse comment with the need to properly explain what happened, and why, in a fair and unbiased manner.

Developing safety action

Central to the ATSB's investigation of transport safety matters is the early identification of safety issues in the transport environment. The ATSB prefers to encourage the relevant organisation(s) to initiate proactive safety action that addresses safety issues. Nevertheless, the ATSB may use its power to make a formal safety recommendation either during or at the end of an investigation, depending on the level of risk associated with a safety issue and the extent of corrective action undertaken by the relevant organisation.

When safety recommendations are issued, they focus on clearly describing the safety issue of concern, rather than providing instructions or opinions on a preferred method of corrective action. As with equivalent overseas organisations, the ATSB has no power to enforce the implementation of its recommendations. It is a matter for the body to which an ATSB recommendation is directed to assess the costs and benefits of any particular means of addressing a safety issue.

When the ATSB issues a safety recommendation to a person, organisation or agency, they must provide a written response within 90 days. That response must indicate whether they accept the recommendation, any reasons for not accepting part or all of the recommendation, and details of any proposed safety action to give effect to the recommendation.

The ATSB can also issue safety advisory notices suggesting that an organisation or an industry sector consider a safety issue and take action where it believes it appropriate. There is no requirement for a formal response to an advisory notice, although the ATSB will publish any response it receives.

Australian Transport Safety Bureau

Enquiries 1800 020 616

Notifications 1800 011 034

REPCON 1800 011 034

Web www.atsb.gov.au

Twitter @ATSBinfo

Email atsbinfo@atsb.gov.au

Investigation

ATSB Transport Safety Report Rail Occurrence Investigation

Derailment of Sydney Trains Passenger Train 602M near Edgecliff station, Sydney, NSW, 15 January 2014

RO-2014-001

Final – 3 December 2015